

Deegelman

"BEST IN THE FIELD --- WHERE IT COUNTS"

OWNERS

&

PARTS MANUAL

PRONG TYPE

ROCK PICKER

MANUAL PART # 142023

farm implements

DEEGELMAN INDUSTRIES LTD.

BOX 830 REGINA SASK CANADA

CONGRATULATIONS ON THE PURCHASE OF YOUR NEW DEGELMAN ROCK PICKER. THIS MACHINE WAS CAREFULLY DESIGNED, PROFESSIONALLY ENGINEERED, TESTED AND MANUFACTURED WITH QUALITY MATERIALS AND SKILLED WORKMANSHIP. IT WILL REWARD YOU WITH SUPERIOR RESULTS AND YEARS OF DEPENDABLE SERVICE IF PROPER MAINTENANCE, CARE AND ADJUSTMENTS ARE PERFORMED.

TO KEEP YOUR ROCK PICKER WORKING EFFICIENTLY, READ AND FOLLOW THE INSTRUCTIONS CONTAINED IN THIS OWNER'S MANUAL. THE TABLE OF CONTENTS WILL ASSIST YOU TO FIND THE REQUIRED INFORMATION.

RIGHT HAND AND LEFT HAND SIDES ARE DETERMINED BY FACING IN THE DIRECTION OF MACHINE FORWARD TRAVEL.

RECORD AND KEEP HANDY YOUR 'ROCK PICKER' SERIAL NUMBER. THIS INFORMATION IS NEEDED BY YOUR AUTHORIZED DEGELMAN DEALER TO PROVIDE YOU WITH REPLACEMENT PARTS, ATTACHMENTS AND REPAIR SERVICES IN A PROMPT AND EFFICIENT WAY.



THIS SAFETY ALERT SYMBOL IDENTIFIES IMPORTANT SAFETY MESSAGES IN THIS MANUAL. WHEN YOU SEE THIS SYMBOL, BE ALERT TO THE POSSIBILITY OF PERSONAL INJURY, THEREFORE, PLEASE CAREFULLY READ THE MESSAGE THAT FOLLOWS.

DEGELMAN INDUSTRIES LTD.

BECAUSE WE ARE CONSTANTLY STRIVING TO IMPROVE OUR PRODUCTS, WE RESERVE THE RIGHT TO INCORPORATE ANY CHANGES RELATED TO DESIGN, MATERIALS AND SPECIFICATIONS AT ANY TIME, WITHOUT NOTICE OR OBLIGATION.

COPYRIGHT © 1979 DEGELMAN INDUSTRIES LTD.

PRINTED IN CANADA

OWNER'S MANUAL SECTION

	<u>PAGE</u>
* WARRANTY INFORMATION	2
* SAFETY SUGGESTIONS	3-4
* ASSEMBLY PROCEDURE:	
INSTALLING:	
I - HITCH POLE ASSEMBLY	5
II - TELESCOPIC JACK	5
III - HITCH POLE HYDRAULIC HOSES	6
IV - WHEEL HUBS AND SPINDLES	6
* OPERATING INSTRUCTIONS:	
- BEFORE STARTING	7
- ROCK PICKER TRANSPORTATION	7
- FIELD OPERATIONS	7-8
- REMOVING TRANSPORT PINS	8
* LUBRICATION CHART AND RECOMMENDATIONS	9
* MAINTENANCE OPERATIONS AND RECOMMENDATIONS	10
* ADJUSTMENT PROCEDURES	10-11
* TROUBLE SHOOTING	12
* SERVICE AND REPAIR PROCEDURES:	
- WHEEL HUB BEARING REPLACEMENT AND ADJUSTMENT	13-14
- HYDRAULIC CYLINDERS	14-15
- REPLACING GRILL TINES	16

PARTS MANUAL SECTION

	17
* FRAME AND HOPPER BOX	18
* WHEEL, HUB AND SPINDLE ASSEMBLY	19
* HITCH POLE	20
* HYDRAULIC LIFT MECHANISM	21
* PICKING GRILL ASSEMBLY	22
* HYDRAULIC SYSTEM	23
* HYDRAULIC CYLINDER 2-1/2 X 31	24

DEGELMAN INDUSTRIES LTD. WARRANTS ITS PRODUCTS TO THE ORIGINAL OWNER FOR A PERIOD OF ONE YEAR FROM THE DATE OF PURCHASE. ALL MATTERS RELATED WITH THE WARRANTY OF OUR PRODUCTS MUST BE HANDLED THROUGH THE AUTHORIZED SELLING DEALER. WARRANTY DOES NOT COVER NORMAL WEAR OF THE MACHINE COMPONENTS OR DAMAGES CAUSED BY LACK OF MAINTENANCE OR MISUSE, AND IS SUBJECT TO THE FOLLOWING PROVISIONS:

* TIRES:

WILL BE ADJUSTED FOR WARRANTY BY THE TIRE MANUFACTURER.

* REPLACEMENT PARTS:

WILL BE WARRANTED FOR A PERIOD OF 90 DAYS.

* LABOUR:

ANY LABOUR SUBJECT TO WARRANTY MUST BE AUTHORIZED BY A DEGELMAN INDUSTRIES LTD. REPRESENTATIVE, BEFORE WORK IS STARTED. WARRANTY LABOUR ALLOWANCE AND RATES WILL BE HANDLED ACCORDING TO ESTABLISHED SERVICE WARRANTY POLICY.

* WARRANTY PARTS:

DEFECTIVE PARTS ARE TO BE STORED AT THE DEALERSHIP AND WARRANTY WILL BE SUBJECT TO INSPECTION BY A DEGELMAN INDUSTRIES LTD. REPRESENTATIVE.

* WARRANTY ON MACHINES USED FOR CUSTOM WORK, RENTAL OR INDUSTRIAL USE:

WARRANTY ON MACHINES USED FOR CUSTOM WORK, RENTAL OR INDUSTRIAL USE SHALL BE AS STATED ABOVE, WITH THE EXCEPTION THAT IT SHALL BE FOR A PERIOD OF 90 DAYS ONLY.

* GOVERNMENT LEGISLATION:

WARRANTY TERMS AND CONDITIONS ARE SUBJECT TO PROVINCIAL OR STATE LEGISLATION.

* WARRANTY WILL BE VOID IF ANY ROCK PICKER COMPONENT IS ALTERED OR MODIFIED, UNLESS WRITTEN AUTHORIZATION IS GRANTED BY DEGELMAN INDUSTRIES LTD.

* WARRANTY APPLIES ONLY TO THE DEGELMAN ROCK PICKER. DEGELMAN INDUSTRIES LTD. WILL NOT ASSUME ANY RESPONSIBILITY FOR WHATEVER DAMAGE MAY OCCUR TO EQUIPMENT TO WHICH THE ROCK PICKER MAY BE ATTACHED.

THE SAFETY OF THE OPERATOR WAS ONE OF THE PRIME CONSIDERATIONS IN THE MINDS OF THE ENGINEERS WHEN THIS ROCK PICKER WAS DESIGNED. SIMPLE ADJUSTMENTS AND SAFETY FEATURES WERE BUILT INTO THE MACHINE WHEREVER POSSIBLE. NEVERTHELESS, ORDINARY CAUTION MUST BE TAKEN WHEN OPERATING THE ROCK PICKER. THERE IS NO SUBSTITUTE FOR A CAREFUL AND SAFETY-MINDED OPERATOR:



- * BEFORE OPERATING THE ROCK PICKER, BE SURE NO ONE IS STANDING NEAR IT.
- * ONLY ONE PERSON, THE OPERATOR, SHOULD BE ALLOWED ON THE MACHINE-TRACTOR COMBINATION WHILE IT IS BEING OPERATED.
- * LOWER THE GRILL TO THE GROUND, PLACE THE HOPPER BOX IN RESTED POSITION AND SHUT OFF THE TRACTOR ENGINE BEFORE ADJUSTING, SERVICING, OR LUBRICATING THE MACHINE. NEVER ALLOW ANYONE TO WORK UNDER A RAISED GRILL OR HOPPER BOX.
- * NEVER OPERATE THE ROCK PICKER EXCEPT FROM THE TRACTOR SEAT.
- * DO NOT OPERATE THE TRACTOR-ROCK PICKER COMBINATION ON STEEP SIDE HILLS. USE TRACTOR LOW GEAR WHEN OPERATING OVER STEEP INCLINES.
- * WHEN OPERATING THE ROCK PICKER, BE SURE TO AVOID CATCHING HYDRAULIC HOSES ON SHARP OBJECTS. ESCAPING FLUID UNDER PRESSURE CAN HAVE SUFFICIENT FORCE TO PENETRATE THE SKIN, CAUSING SERIOUS PERSONAL INJURY. BEFORE DISCONNECTING LINES, BE SURE TO RELIEVE ALL PRESSURE TO THE SYSTEM, BE SURE ALL CONNECTIONS ARE TIGHT AND THAT LINES AND HOSES ARE NOT DAMAGED. FLUID ESCAPING FROM A VERY SMALL HOLE CAN BE ALMOST INVISIBLE.
- * IF INJURED BY ESCAPING FLUID, SEE A DOCTOR AT ONCE. SERIOUS INFECTION OR REACTION CAN DEVELOP IF PROPER MEDICAL TREATMENT IS NOT ADMINISTERED IMMEDIATELY.
- * WHEN TRANSPORTING THE ROCK PICKER ON A ROAD OR HIGHWAY, BE SURE THE TRANSPORT PINS ARE IN PLACE AND HAVE THE HITCH POLE FACE INWARD. (TRANSPORT POSITION). DO NOT EXCEED SAFE TRAVELLING SPEED OF 32 KPH (20 MPH), OR LESS DEPENDING ON ROAD CONDITIONS. CHECK LOCAL GOVERNMENT REGULATIONS REGARDING THE USE OF ACCESSORY LIGHTS AND SAFETY DEVICES FOR ADEQUATE WARNING TO OPERATORS OF OTHER VEHICLES. THIS EQUIPMENT IS AVAILABLE AT DIFFERENT SOURCES.
- * DO NOT EXCEED RECOMMENDED TIRE PRESSURE. USE CARE AND CAUTION WHEN SERVICING AND INFLATING TIRES TO PREVENT PERSONAL INJURY FROM BLOW-OUT.
- * FREQUENTLY CHECK AND RETIGHTEN BOLTS TO SPECIFIED TORQUES SHOWN IN SERVICE AND REPAIR SECTION .

SAFETY SUGGESTIONS

SAFETY DECALS

SOME OR ALL OF THE FOLLOWING SAFETY DECALS MAY BE FOUND AT STRATEGIC LOCATIONS ON THIS MACHINE. THESE DECALS ARE INSTALLED WITH THE PURPOSE OF ALERTING EVERYONE OF POTENTIAL DANGER OR DAMAGE.



THIS DANGER DECAL IS LOCATED ON THE HOPPER BOX SIDE PANELS AS WELL AS AT THE BACK PANEL.

THE PURPOSE OF THE DECAL LEGEND IS TO PREVENT EVERYONE FROM BEING NEAR THE MACHINE WHEN IN OPERATION.



THIS CAUTIONARY DECAL IS ATTACHED TO THE FRONT SIDE OF BOTH GRILL HYDRAULIC LIFT ARMS.

THE PURPOSE OF THE DECAL LEGEND IS TO REMIND THE OPERATOR TO REMOVE THE TRANSPORT PINS AFTER THE MACHINE IS TRANSPORTED TO THE FIELD, AND BEFORE THE GRILL IS LOWERED TO PICK ROCKS.

FOREWORD:

THE DEGELMAN PRONG TYPE ROCK PICKER IS A PULL-BEHIND MACHINE, CAPABLE OF SPOT PICKING AND BOULDER REMOVAL.

THE DOUBLE ACTING HYDRAULIC CYLINDERS PERFORM TWO JOBS; THEY LIFT AND CONTROL THE PICKING GRILL AND ALSO, THEY LIFT THE HOPPER BOX TO DUMP THE ROCKS.

ASSEMBLY PROCEDURE

AS RECEIVED, PLACE THE MACHINE ON TOP OF TWO 4 X 4 IN. WOODEN PLANKS LAYED LENGTHWISE ON LEVELLED GROUND.

I - INSTALLING THE HITCH POLE

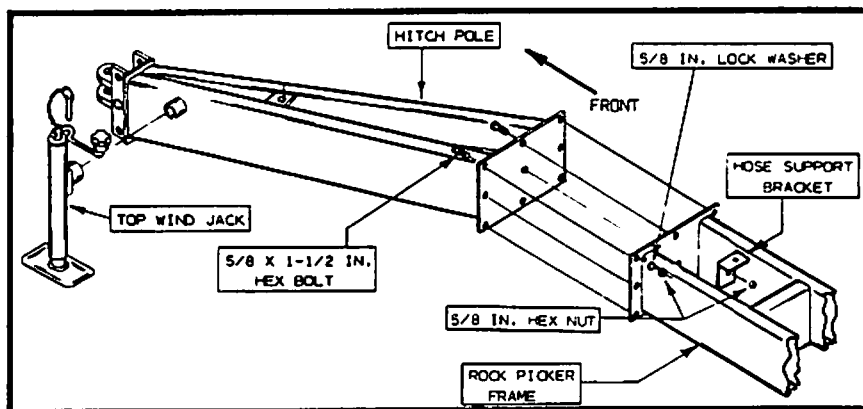

THE HITCH POLE MAY BE ATTACHED TO THE PRONG PICKER FRAME IN TWO DIFFERENT POSITIONS:

FIGURE # 1

* OFFSET TO THE CENTRE, RECOMMENDED WHEN THE MACHINE IS TO BE HAULED FOR LONG DISTANCE OR ON THE HIGHWAY,

* OFFSET TO THE LEFT HAND SIDE, REQUIRED FOR FIELD OPERATION.

INSTALL HITCH POLE TO PICKER FRAME FRONT MOUNTING PLATE, USING SOME WOODEN BLOCKS TO MAINTAIN AN APPROPRIATE HEIGHT. MAKE THE ATTACHING HOLES COINCIDE AND INSTALL NINE 5/8 X 1-1/2 IN. HEX BOLTS, LOCK WASHERS AND HEX NUTS. WHILE INSTALLING THE UPPER CENTRE BOLT, ATTACH THE HOSE SUPPORT BRACKET, AS SHOWN IN FIGURE # 1.

II - INSTALLING THE TELESCOPIC JACK

IN FULLY RETRACTED POSITION ATTACH THE TELESCOPIC JACK TO THE MOUNTING SOCKET ON THE LEFT SIDE OF THE HITCH POLE AND SECURE WITH THE CHAINED PIN. REFERENCE FIGURE #1. THEN, EXTEND THE JACK FOOT STAND TO TOUCH THE GROUND.

NOTE: ONCE THE ROCK PICKER IS READY FOR OPERATION AND HITCHED TO THE TRACTOR, RAISE THE JACK FOOT STAND FROM GROUND, REMOVE CHAINED PIN, ROTATE THE JACK ASSEMBLY TO A HORIZONTAL POSITION AND REINSTALL THE CHAINED PIN TO SECURE THE JACK ASSEMBLY TO THE HITCH POLE.

ASSEMBLY

SECURING HYDRAULIC HOSES TO HITCH POLE

CUT OFF PLASTIC TIES FOR SHIPPING PROTECTION AND UNFOLD HOSES TOWARD THE HITCH POLE CLEVIS. USING HOSE CLIP (1), 5/16 X 1-1/2 IN. HEX BOLT (2), LOCK WASHER (3) AND HEX NUT (4), ATTACH HOSES TO BRACKET (5). ATTACH HOSES TO HITCH POLE USING HOSE CLIP (6), 5/16 X 1-1/2 IN. BOLT (7), 3/8 IN. FLAT WASHER (8) AND HEX NUT (9). REFERENCE FIGURE #2.

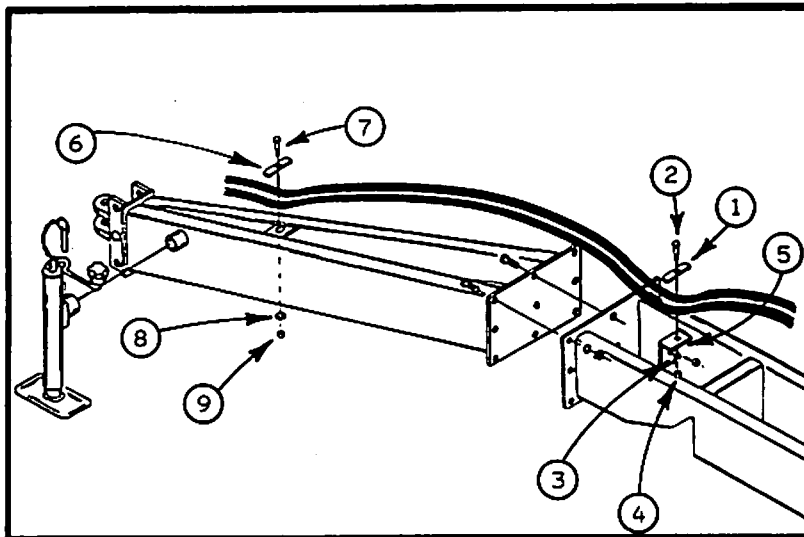

FIGURE # 2

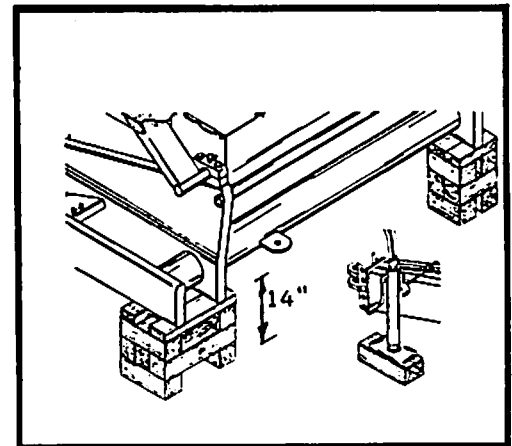

FIGURE # 3

III - INSTALLING THE WHEEL, HUB AND SPINDLE ASSEMBLIES.

BEFORE INSTALLING THE WHEEL, HUB AND SPINDLE ASSEMBLIES, BLOCK-UP THE PRONG TYPE ROCK PICKER FRAME TO A HEIGHT OF 14 INCHES EVENLY, AS SHOWN IN FIGURE # 3. OTHER ALTERNATE METHODS OF LIFTING THE MACHINE MAY BE USED, AS LONG AS THEY PROVIDE SAFE OPERATIONS.

CHECK THE HUB SPINDLES FOR TRANSPORTATION DAMAGE AND/OR PAINT EXCESS AND CORRECT AS REQUIRED. CLEAN THE INSIDE OF THE FRAME SPINDLE TUBES AND LOOSEN THE 5/8 X 1-1/2 IN. SET SCREWS AND JAM NUTS. REFERENCE FIGURE # 4.

FULLY INSERT THE HUB SPINDLES INTO THE FRAME SPINDLE TUBES AND TIGHTEN THE SET SCREWS AND JAM NUTS. THEN, INSTALL A RIM AND TIRE ASSEMBLY TO EACH SPINDLE HUB USING SIX 9/16 X 1-1/16 IN. WHEEL BOLTS. TIGHTEN THE WHEEL BOLTS TO 105 FT-LB TORQUE.

NOTE: FIGURE # 4 SHOWS THE RIGHT HAND SIDE HUB AND SPINDLE ASSEMBLY INSTALLATION. THE LEFT HAND SIDE IS SYMMETRICAL.

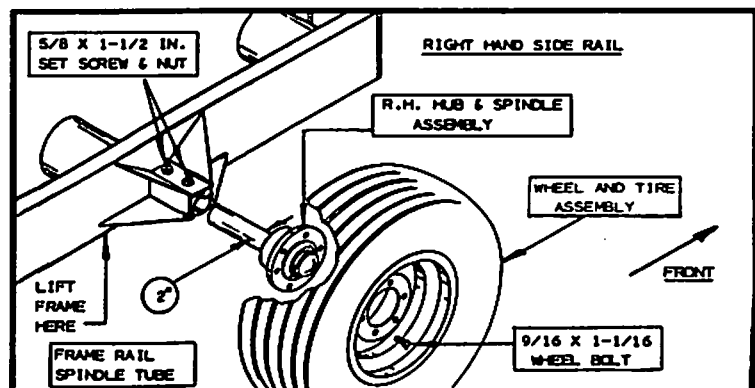

FIGURE # 4

BEFORE STARTING OPERATIONS:

- SET THE TIRE AIR PRESSURE TO 45 POUNDS.
- MAKE SURE THE ROCK PICKER IS PROPERLY LUBRICATED ACCORDING TO INSTRUCTIONS PROVIDED IN THE LUBRICATION PROCEDURE SECTION. THIS IS VERY IMPORTANT ESPECIALLY WHEN STARTING SEASONAL OPERATIONS.
- PIN THE TRACTOR DRAW BAR TOTALLY OFFSET TO THE RIGHT HAND SIDE, TO ALLOW THE PICKING GRILL TO CLEAR THE TRACTOR WHEELS AND HOOK THE PICKER HITCH POLE CLEVIS TO THE TRACTOR DRAW BAR USING A PROPER HITCH PIN.
- RAISE THE TELESCOPIC HITCH POLE JACK AND SWING IT TO THE HORIZONTAL POSITION.
- HOOK-UP THE ROCK PICKER HYDRAULIC HOSES TO THE TRACTOR REAR OUTLET CONNECTIONS AS FOLLOWS:

CONNECT THE HOSES THAT OPERATE THE GRILL LIFTING CYLINDERS TO THE HYDRAULIC CONTROL OPERATED NEAREST TO THE OPERATOR'S SEAT, SUCH THAT WHEN THE LEVER IS MOVED FORWARD, THE GRILL WILL LOWER.

- START THE TRACTOR ENGINE AND OPERATE THE HYDRAULIC CONTROL LEVER JUST TO CONFIRM THAT THEY WERE HOOKED-UP AS OUTLINED ABOVE.
- CHECK THAT THE TRANSPORT PINS ARE REMOVED. IF THEY ARE STILL INSTALLED, PROCEED TO REMOVE THEM AS OUTLINED IN PAGE # 8.



CAUTION: WHEN PERFORMING THE LIFTING AND DUMPING OPERATIONS WITH THE HOPPER BOX, DO NOT ALLOW ANYBODY TO STAND CLOSE BY.

- CHECK THE TRACTOR HYDRAULIC FLUID RESERVOIR LEVEL AND ADD TO COMPENSATE WHATEVER AMOUNT OF FLUID WAS UTILIZED TO FILL THE ROCK PICKER HYDRAULIC CYLINDERS AND HOSES.

ROCK PICKER TRANSPORTATION

WHEN TRANSPORTING THE ROCK PICKER ON ROADS OR HIGHWAYS:

- ALWAYS INSTALL THE TRANSPORT PINS. FOR INSTALLATION PROCEDURE REFER TO THE SERVICE AND REPAIR PROCEDURE.
- REVERSE THE HITCH POLE OFFSET POSITION TOWARDS THE MACHINE CENTER LINE.
- DO NOT EXCEED 32 KPH (20 MPH) ROAD SPEED.

FIELD OPERATIONS

- BEGIN THE ROCK PICKING OPERATIONS AND OBSERVE THE MACHINE'S PERFORMANCE REGARDING THE PARTICULAR FIELD CONDITIONS BEFORE ATTEMPTING ANY ADJUSTMENTS.
- ON NEW MACHINES, IT IS ADVISABLE TO MAKE A COMPLETE CHECK AFTER ONE OR TWO HOURS OF OPERATION. VERIFY THAT ALL FASTENERS ARE TIGHT ENOUGH, ESPECIALLY WHEEL BOLTS AND SET SCREWS. ALSO, RECHECK THAT ADJUSTMENTS ARE MAINTAINED AS SET.
- REMEMBER THAT ROCK PICKERS ARE DESIGNED AND BUILT TO REMOVE ROCKS AND OTHER DEBRIS FROM THE GROUND SURFACE, BUT NOT TO PULL OUT BURIED MATERIAL.
- THE BEST ROCK PICKING CONDITIONS ARE WHEN THE ROCKS LAY ON THE GROUND SURFACE AND IT IS REASONABLY FIRM AND DRY.

OPERATION

- IF THE GROUND SURFACE IS BUMPY, DO NOT LOAD THE MACHINE TOO HEAVY AND REDUCE MACHINE'S TRAVEL SPEED.
- THE HITCH POLE CLEVIS IS NORMALLY LOCATED IN THE HITCH POLE BRACKET CENTRE POSITION. THIS SETTING ALLOWS THE ROCK PICKER FRAME AND POLE ASSEMBLY TO RIDE PARALLEL TO THE GROUND. HOWEVER, IF THE SOIL IS FOUND TO BE RATHER SOFT, ADJUST THE CLEVIS CASTING AT THE HITCH POLE BRACKETS, SUCH THAT THE FRAME AND POLE ASSEMBLY WOULD BE LEVELLED TO THE GROUND.
- FOR INFORMATION REGARDING COMPONENT ADJUSTMENTS, MAKE REFERENCE TO THE ADJUSTMENT PROCEDURES SECTION.

REMOVING THE TRANSPORT PINS

ONCE THE HYDRAULIC SYSTEM OF THE ROCK PICKER IS OPERABLE, RAISE THE PICKER GRILL ASSEMBLY (1) UNTIL THE SLANTED EDGE IS IN A HORIZONTAL POSITION. THEN BLOCK-UP THE GRILL AS SHOWN IN FIGURE # 5.

OPERATE THE HYDRAULIC CONTROL LEVER TO PRODUCE A SLIGHT DOWNWARD MOVEMENT OF THE GRILL HYDRAULIC LIFT ARMS (2), SUCH THAT THE TRANSPORT PINS (3) MAY BE RELIEVED FROM LOAD APPLIED BY THE GRILL LIFT PLATE (4). REFERENCE FIGURE # 5. REMOVE AND KEEP TRANSPORT PINS (3) TO USE WHENEVER REQUIRED.

RAISE THE HYDRAULIC LIFT ARMS (2) AGAIN, UNTIL THE HYDRAULIC LIFT ARM STOP BLOCKS (5) CONTACT THE GRILL LIFT PLATE (4), AS SHOWN IN FIGURE # 6. REMOVE THE WOODEN BLOCKS FROM UNDER THE GRILL AND LOWER THE PICKER GRILL (1) TO THE GROUND.

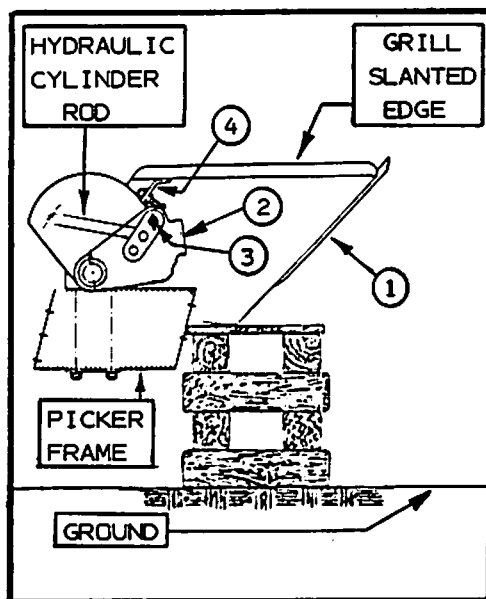

FIGURE # 5

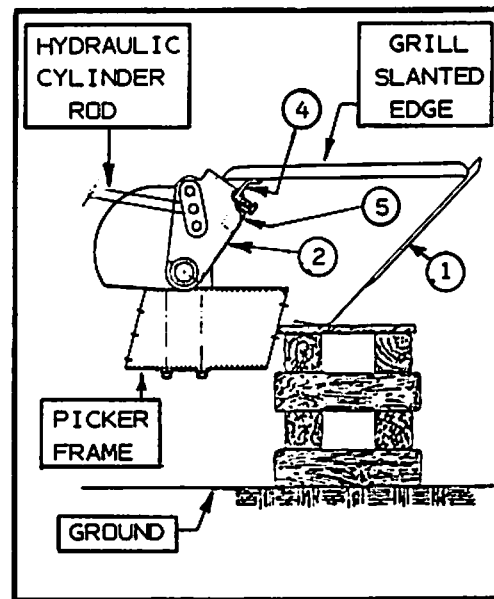

FIGURE # 6

LUBRICATION RECOMMENDATIONS CHART

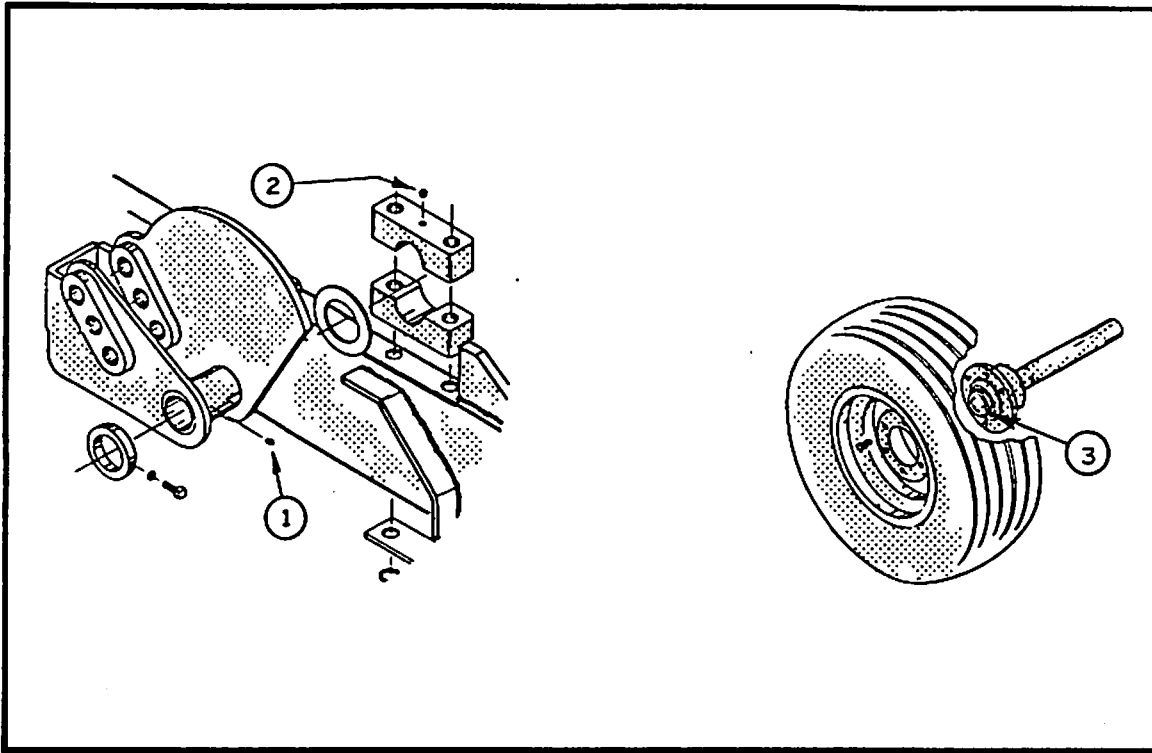

FIGURE # 7

<u>KEY</u>	<u>POINTS OF LUBRICATION</u>	<u>FREQUENCY</u>	<u>METHOD</u>	<u>AMOUNT</u>
1	HYDRAULIC LIFT ARM (RH & LH)	DAILY	GREASE GUN	ONE STROKE
2	BEARING HALF CASTING (HYD. LIFT ARM SHAFT (RH & LH)	DAILY	GREASE GUN	ONE STROKE
3	WHEEL BEARINGS (RH & LH)	SEASONALLY	REPACK	AS REQUIRED.

RECOMMENDED LUBRICATION MATERIAL

USE GOOD QUALITY BEARING GREASE TO LUBRICATE ALL GREASE FITTINGS WITH SUITABLE GREASE GUN AND TO REPACK WHEEL BEARINGS.

NOTE: DURING PROLONGED STORAGE PERIODS, COAT EXPOSED HYDRAULIC CYLINDER RODS WITH LIGHT OIL TO PREVENT POSSIBLE CORROSION.

MAINTENANCE OPERATIONS

DUE TO THE WIDE RANGE OF OPERATIONAL CONDITIONS THAT THE MACHINE WILL BE SUBJECTED, IT IS DIFFICULT AND RATHER COMPLEX TO SPECIFY MAINTENANCE REQUIREMENTS FOR A GIVEN TIMING. THEREFORE, THE FOLLOWING MAINTENANCE RECOMMENDATIONS ARE TO BE ONLY A GUIDE. FREQUENCIES AND REQUIREMENTS MAY BE VARIED TO SUIT LOCAL NEEDS.

RECOMMENDATIONS

- ALWAYS USE CLEAN HYDRAULIC FLUID AND PERIODICALLY CHECK FOR LEAKS.
- PERFORM COMPLETE LUBRICATION OPERATIONS ON THE MACHINE AT THE END AND THE BEGINNING OF EVERY SEASON. SEE LUBRICATION CHART ON PAGE # 9.
- REPACK AND ADJUST WHEEL BEARINGS AT THE BEGINNING OF EVERY SEASON. SEE ADJUSTMENT METHOD AT THE SERVICE AND REPAIR PROCEDURE SECTION, PAGE # 13.

CHECK:

	DAILY	MONTHLY	SEASONALLY	
			START	END
HYDRAULIC FLUID LEAKS	X		X	X
BEARING BLOCK CONDITION		X	X	X
GRILL TINE WEAR/SHAPE		X	X	OR X
TIRE PRESSURE	X		X	
WHEEL RIM BOLTS TIGHT		X	X	
STRUCTURAL COMPONENTS BOLTS AND NUTS TIGHT		X	X	
GRILL TINE BOLTS TIGHT		X	X	

FOR LUBRICATION: PLEASE SEE LUBRICATION PROCEDURE - PAGE 9

ADJUSTMENT PROCEDURES

GRILL DEPTH CONTROL STOP ADJUSTMENT

BEFORE ATTEMPTING A FINAL ADJUSTMENT FOR THE GRILL DEPTH CONTROL STOP, IT IS VERY IMPORTANT TO SET THE HITCH POLE FIRST, IN VIEW OF THE LARGE VARIETY OF TRACTOR DRAWBAR SHAPES AND HEIGHTS.

THEREFORE, PROCEED TO MAKE THE NECESSARY ADJUSTMENTS, WHETHER AT THE HITCH POLE CLEVIS OR AT THE TRACTOR DRAWBAR, TO GET THE HITCH POLE PARALLEL TO THE GROUND LEVEL. REFERENCE FIGURE # 8.

IMPORTANT: MAKE SURE THE ROCK PICKER TIRES HAVE THE SPECIFIED AIR PRESSURE (45 LB/SQ. IN.)

THE GRILL DEPTH FINAL ADJUSTMENT SHOULD BE SUCH THAT THE TOE OF THE GRILL TINES, WOULD SKIM THE GROUND AND AT THE SAME TIME, THE HEEL OF THE GRILL TINES SHOULD BE ABOUT 1/2 IN. ABOVE THE GROUND LEVEL. REFERENCE FIGURE # 8.

ADJUSTMENT PROCEDURES (CONTINUED)

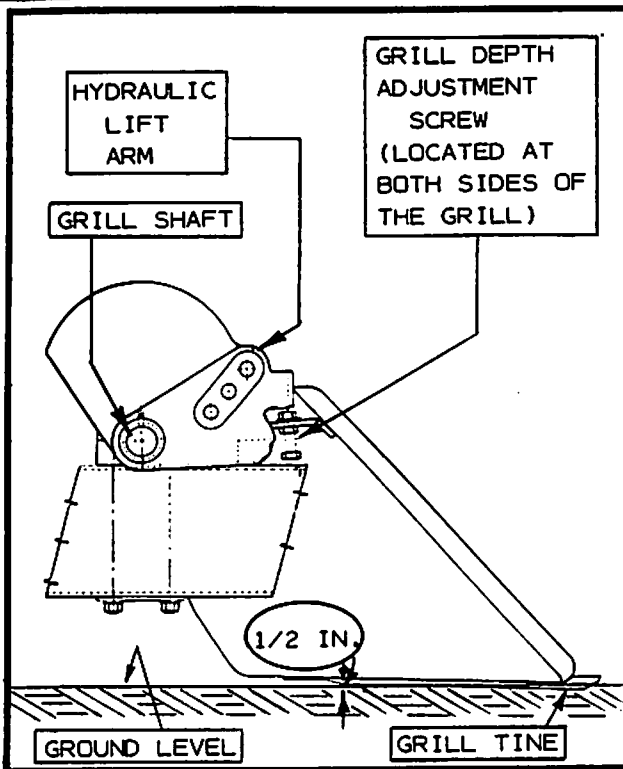

FIGURE #8

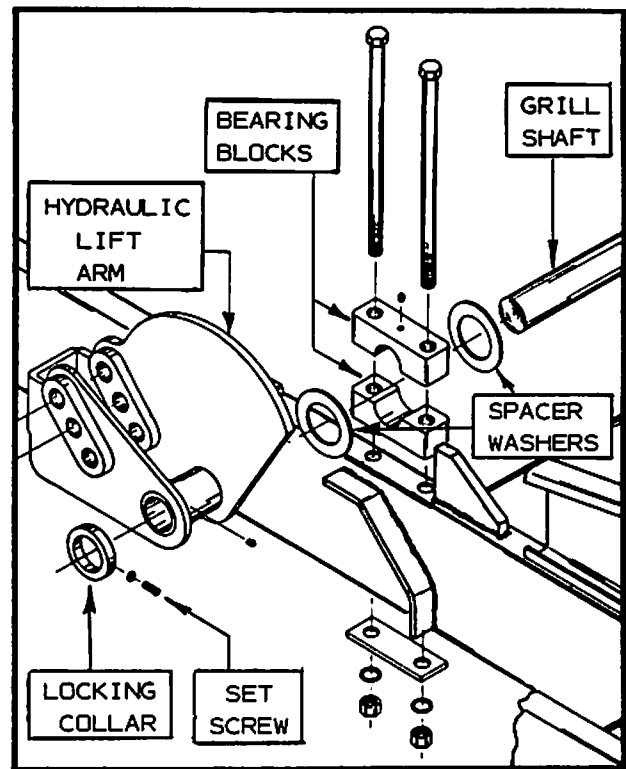

FIGURE #9

GRILL SHAFT LOCKING COLLAR ADJUSTMENT

THE LOCKING COLLARS LOCATED AT BOTH ENDS OF THE GRILL SHAFT SHOULD ONLY BE FITTED SNUG, ALLOWING THE HYDRAULIC LIFT ARMS TO MOVE FREE. KEEP THE LOCKING COLLAR SET SCREWS AND JAM NUTS TIGHT. REFERENCE FIGURE # 9.

THE GRILL SHAFT HAS FOUR SPACER WASHERS WHICH MAY EVENTUALLY SHOW SOME WEAR DUE TO THRUST. REPLACE THESE SPACER WASHERS WHEN SIGNIFICANT WEAR IS VISIBLE.

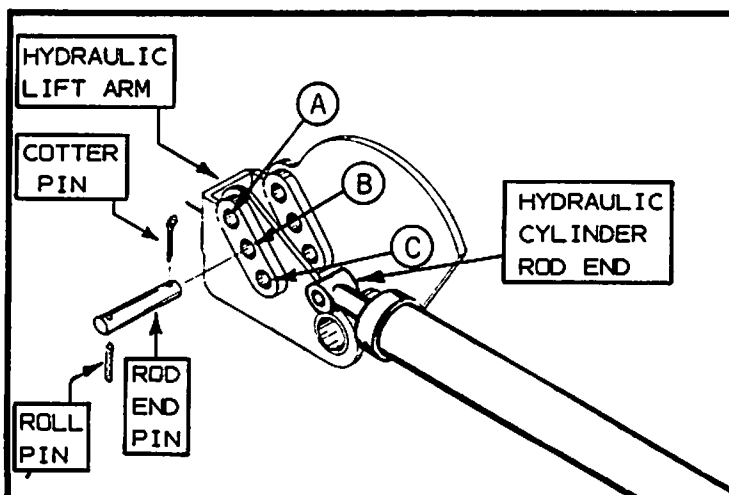

FIGURE #10

HYDRAULIC CYLINDER ROD END TO LIFT ARM SETTING

WHEN LOCATING THE ROD END IS POSITION (A) THE LIFTING CAPACITY OF THE GRILL WILL INCREASE, BUT THE LIFTING SPEED WILL BE REDUCED.

WHEN CHOOSING THE POSITION (C), THE LIFTING SPEED WOULD BE INCREASED, BUT THE LIFTING CAPACITY WOULD BE REDUCED.

POSITION (B) IS AN INTERMEDIATE OF THE ABOVE DESCRIBED POSITIONS.

THE ROCK PICKER SHOULD PERFORM SMOOTHLY AND EFFICIENTLY. IF AFTER FOLLOWING THE OPERATING INSTRUCTIONS IN THIS MANUAL AND CHECKING THE PICKER FOR PROPER ASSEMBLY DIFFICULTIES STILL PERSIST, USE THE FOLLOWING CHART TO FIND THE POSSIBLE CAUSE AND REMEDY. IF THE TROUBLE IS NOT CORRECTED, CONSULT YOUR DEGELMAN DEALER.

SYMPTON	POSSIBLE CAUSE	REMEDY
PICKING UP EXCESS DIRT.	GRILL DEPTH TOO LOW.	RAISE GRILL BY ADJUSTING GRILL DEPTH ADJUSTING SCREW.
	EXCESS FIELD TRASH.	
GRILL CREEPS DOWN	HYDRAULIC CYLINDER LEAKS.	REPLACE SEALS.
	POOR TRACTOR HYDRAULIC SYSTEM.	CHECK AND REPAIR.
GRILL LIFTING TOO SLOWLY.	HYDRAULIC CYLINDER RODS NOT POSITIONED CORRECTLY AT LIFTING ARMS.	ADJUST TO ACHIEVE PROPER LIFTING SPEED.
	HYDRAULIC CYLINDERS HAVE INTERNAL LEAKS.	REPLACE PISTON SEALS.
GRILL WILL NOT LAY FLAT ON THE GROUND.	SOFT GROUND.	ADJUST GRILL DEPTH.
	INCORRECT TIRE PRESSURE.	INFLATE TO 45 LBS.
WILL NOT LIFT LARGE ROCKS.	EXCEEDING LIFTING CAPABILITIES OF HYDRAULIC CYLINDER.	PIN HYDRAULIC CYLINDER INTO TOP HOLE OF LIFTING ARM.
	HYDRAULIC CYLINDER INTERNAL LEAKS.	REPLACE PISTON SEALS.
	POOR TRACTOR HYDRAULIC SYSTEM.	CHECK AND REPAIR.
BOX AND GRILL WILL NOT LIFT.	CROSSED HOSES.	CONNECT IN PROPER SEQUENCE.

WHEEL HUB BEARING REPLACEMENT AND ADJUSTMENT

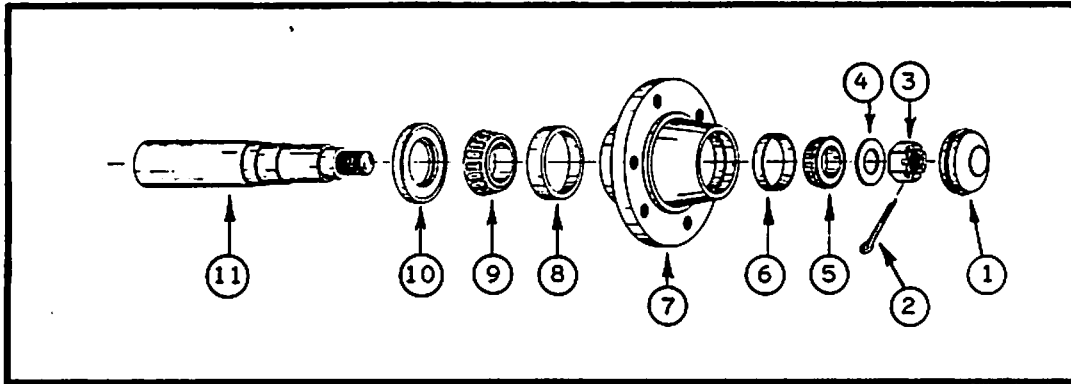



FIGURE # 11

WHEEL HUB BEARING REPLACEMENT AND ADJUSTMENT PROCEDURE

REMOVAL AND DISASSEMBLY OPERATIONS

- LOOSEN WHEEL RIM BOLTS WITH APPROPRIATE WRENCH.
- RAISE WHEEL ASSEMBLY FROM GROUND USING SUITABLE JACK TO LIFT AND BLOCK THE MACHINE PROPERLY. 
- REMOVE ALL WHEEL RIM BOLTS AND WHEEL ASSEMBLY.
- REMOVE DUST CAP (1) FROM WHEEL HUB (7), USING A SCREW DRIVER TO PRY AND TAP GENTLY ON THE DUST CAP RIDGE. REFERENCE FIGURE # 11.
- REMOVE COTTER PIN (2) FROM CASTELLATED NUT (3) AND DISCARD IT.
- REMOVE CASTELLATED ADJUSTING NUT (3) AND FLAT WASHER (4).
- PULL OUT THE HUB CASTING (7), BEING CAREFUL TO CATCH THE OUTER ROLLER BEARING CONE (5).
- PLACE ALL REMOVED PARTS ON A CLEAN BENCH TOP OR SUITABLE TRAY.
- USE A 1/2 X 8 IN. BRONZE BAR OR SIMILAR SOFT MATERIAL TO TAP CAREFULLY ON THE INNER ROLLER BEARING CONE (9) TO REMOVE BOTH THE CONE AND THE DUST SEAL (10).
- WASH ALL REMOVED PARTS WITH CLEAN SOLVENT AND AIR DRY.

NOTE: WHEN AIR DRYING ROLLER BEARING CONES, DO NOT ALLOW THEM TO SPIN, AVOIDING POSSIBLE DAMAGE.

- INSPECT ALL PARTS FOR WEAR AND DAMAGE.
- IF BEARING CUPS NEED TO BE REPLACED, USE A 12 IN. LONG TAPER PUNCH TO HAMMER THE CUPS ON THEIR EDGES ALTERNATELY.
- TO INSTALL BEARING CUP REPLACEMENTS INTO THE HUB CASTING, USE THE TAPER PUNCH TO DRIVE IN THE CUPS (6) AND (8) BY POUNDING ON THEIR EDGE ALTERNATELY AND BEING VERY CAREFUL NOT TO CHIP THE CUPS. MAKE SURE THAT CUPS (6) AND (8) ARE FULLY SEATED.
- APPLY A THICK COAT OF BEARING GREASE INSIDE THE HUB CASTING, AND SOAK THE BEARING CONES (5) AND (9) IN HEAVY OIL, SUCH AS TRANSMISSION OIL. LUBRICATE DUST SEAL LIP (10) WITH A THICK BEAD OF THE SAME OIL.
- INSTALL THE INNER ROLLER BEARING CONE (9) AND NEST IT ON ITS CORRESPONDING BEARING CUP INSIDE OF THE HUB CASTING.

SERVICE & REPAIR

WHEEL HUB BEARING REPLACEMENT AND ADJUSTMENT (CONTINUED)

- NOW INSTALL THE DUST SEAL (10) ON TOP OF THE BEARING CONE (9) JUST ASSEMBLED, SO THAT THE SEAL LIP FACES IN-BOARD AND THE METAL CAGE REMAINS FLUSH WITH THE HUB CASTING EDGE (7). USE THE BRONZE BAR MENTIONED ABOVE TO HAMMER TAP GENTLY ON THE DUST SEAL (10).
- INSERT THE HUB CASTING (7) ONTO THE SPINDLE (11) BEING CAREFUL NOT TO DAMAGE THE DUST SEAL (10) WITH THE SPINDLE STEPS.
- FILL REMAINING HUB CAVITIES WITH BEARING GREASE, TO PROVIDE ADEQUATE LUBRICATION RESERVE.
- HOLDING THE HUB CASTING (7) CENTERED ON THE SPINDLE (11), SLIDE THE OUTER BEARING CONE (5) ONTO THE SAME SPINDLE PUSHING INWARDS.
- INSERT THE FLAT WASHER (4) AND THREAD THE CASTELLATED NUT (3) ON TO THE SPINDLE (11).
- USE A SUITABLE SIZE CRESCENT WRENCH TO SLOWLY TIGHTEN THE NUT (3) AND AT THE SAME TIME, CONSTANTLY ROTATE THE HUB CASTING (7), UNTIL DIFFICULTY OF ROTATION IS FELT. THEN, LOOSEN THE NUT (3) A HALF OF A TURN.
- ROTATE THE HUB CASTING (7) AND FINGER TIGHTEN THE CASTELLATED NUT (3) UNTIL A DRAG CONDITION IS FELT WHILE THREADING.

OBSERVE THE COTTER PIN SPINDLE HOLE POSITION AGAINST THE NUT CASTELLATIONS. IF NO COINCIDENTAL SITUATION WAS OBTAINED, TURN THE NUT (3) BACK JUST ENOUGH TO FIND A CASTELLATION THAT WOULD ALLOW THE NEW COTTER PIN (2) INSTALLATION. HUB CASTING (7) MUST TURN FREE AND MUST NOT HAVE APPRECIABLE END PLAY.

- SLIGHTLY TAP COTTER PIN HEAD (2) AND BEND LEGS SIDEWAYS OVER THE NUT (3), SUCH THAT IT WILL NOT MOVE.
- FILL THE DUST CAP (1) HALF WAY WITH BEARING GREASE AND INSTALL IT ON THE HUB CASTING (7) TAPPING GENTLY, UNTIL THE DUST CAP RIDGE IS SEATED.
- REINSTALL WHEEL ASSEMBLY ONTO HUB CASTING (7) AND HAND TIGHTEN WHEEL BOLTS. THEN, LOWER THE JACK AND RETIGHTEN WHEEL BOLTS ALTERNATELY TO 105 FT-LB. TORQUE.

HYDRAULIC CYLINDERS

IF HYDRAULIC CYLINDER EFFICIENCY DECREASES AND NO EXTERIOR FLUID LEAKAGE IS EVIDENT, THE FOLLOWING STEPS MAY BE TAKEN:

- CHECK THAT THE TRACTOR HYDRAULIC FLUID RESERVOIR HAS SUFFICIENT FLUID.
- REMOVE THE CYLINDER FROM ROCK PICKER AND TEST EACH CYLINDER INDIVIDUALLY.
- FULLY RETRACT THE HYDRAULIC CYLINDER AND THEN DISCONNECT FROM THE CYLINDER THE HOSE THAT NORMALLY SUPPLIES HYDRAULIC FLUID PRESSURE TO EXTEND THE ROD.
- APPLY FLUID PRESSURE TO RETRACTING SIDE OF THE CYLINDER AND AT THE SAME TIME, OBSERVE THE OPEN PORT FOR FLUID FLOW.
- IF A CONTINUOUS STREAM OF FLUID IS FLOWING, THE PISTON SEALS SHOULD BE REPLACED.
- REVERSE THE HOSE CONNECTION AND PERFORM THE SAME TEST, BUT NOW FULLY EXTENDING THE HYDRAULIC CYLINDER AND OBSERVE THE RESULTS.
- IF THE HYDRAULIC CYLINDER TEST RESULTS ARE SATISFACTORY, BUT THE HYDRAULIC FLUID PRESSURE REMAINS DEFICIENT, THEN PROCEED TO REVIEW THE TRACTOR HYDRAULIC SYSTEM.

CYLINDER DISASSEMBLY

- PLUG CYLINDER PORTS AND THOROUGHLY CLEAN COMPLETE CYLINDER.
- LOOSEN END CAP LOCK RING AND UNSCREW END CAP.
- CAREFULLY REMOVE THE PISTON AND ROD ASSEMBLY.
- CLAMP THE EXTERIOR END OF THE ROD ON A VISE TO REMOVE THE PISTON ASSEMBLY.

HYDRAULIC CYLINDER (CONTINUED)

VERY IMPORTANT: DO NOT CLAMP THE CYLINDER ROD BY THE CHROMED SURFACE.

- REMOVE PISTON LOCK NUT AND PISTON AND SLIDE OFF ROD FROM END CAP.
- WASH PARTS WITH CLEAN SOLVENT AND AIR DRY. INSPECT PARTS THOROUGHLY.

CYLINDER ASSEMBLY

NOTE; DO NOT USE SHARP TOOLS TO AID IN INSTALLATION OF COMPONENTS. BE CAREFULL NOT TO DAMAGE SEALS.

- REPLACE ALL SEALS ON PISTON AND END CAP.
- REINSTALL ROD THROUGH END CAP.
- SECURE PISTON TO ROD WITH LOCK NUT. TORQUE TO 225 FT. LBS.
- HOLD CYLINDER BODY IN A VICE AND GENTLY INSERT PISTON AND ROD ASSEMBLY INTO CYLINDER USING A SLIGHT ROCKING MOTION.
- SCREW ON END CAP FULLY UNTIL IT BOTTOMS AGAINST TOP OF CYLINDER. BACK OFF END CAP TO ACHIEVE DESIRED PORT DIRECTION.
- SECURE END CAP BY JAMMING LOCK RING AGAINST END CAP.
- TEST CYLINDER ASSEMBLY, AS DESCRIBED ON PREVIOUS PAGE.

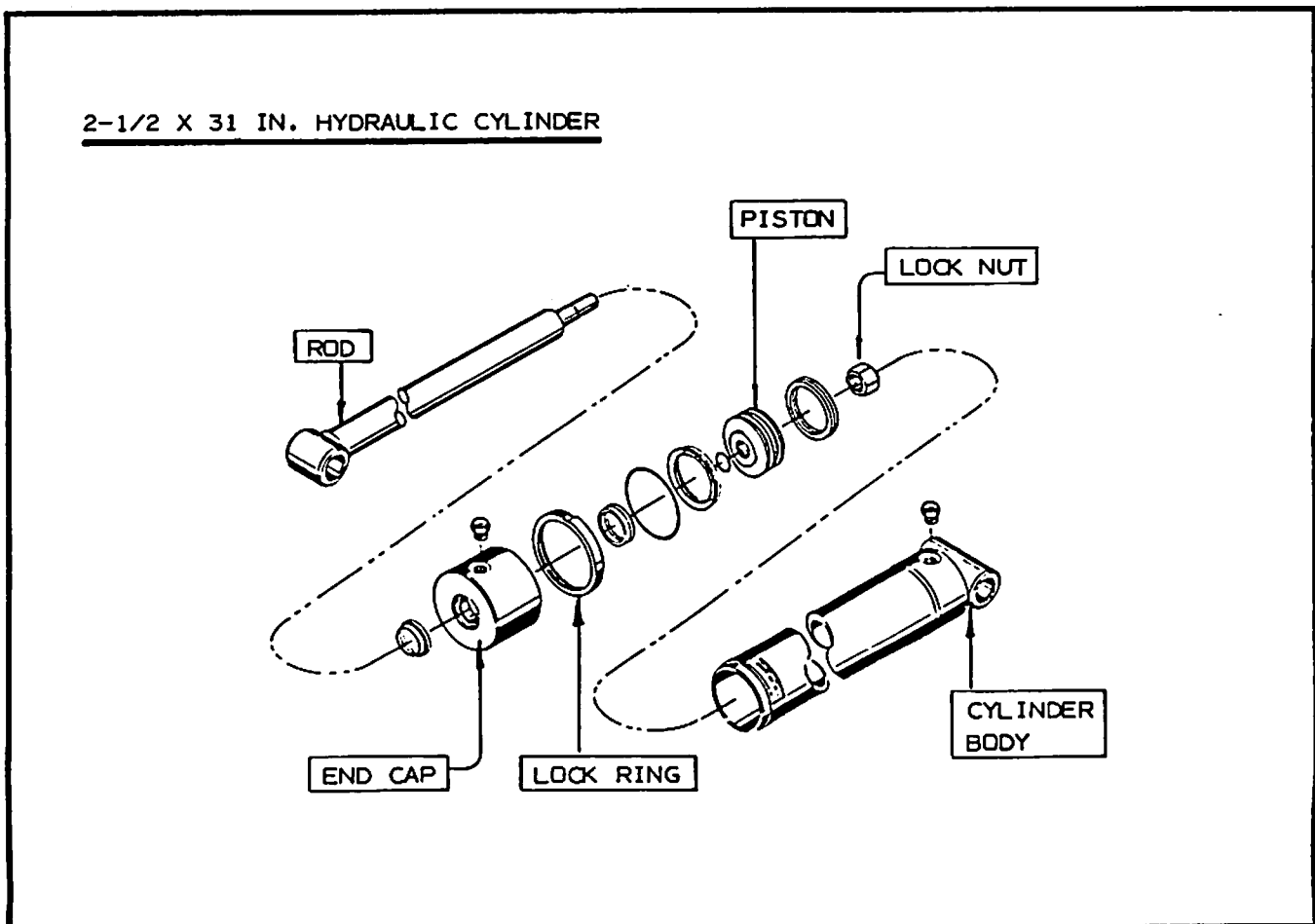

SERVICE & REPAIR

REPLACING THE GRILL TINES

THE GRILL TINES CAN BE REPLACED WITH NEW ONES. IT WILL BE NECESSARY TO REMOVE ALL THE 5/8 X 3 IN. HEX BOLTS (5), LOCK WASHERS AND HEX NUTS WHICH SUPPORT THE GRILL TINE HOLDER BAR (4) AND THE GRILL TINE SPACER BLOCKS (3). THEN, THE GRILL TINES REQUIRING REPLACEMENT MAY BE INDIVIDUALLY DISCONNECTED FROM THE GRILL BY REMOVING THEIR 5/8 X 2-1/2 IN. ATTACHING HEX BOLT (6), LOCK WASHER (7) AND HEX BOLT (8). REFERENCE FIGURE # 13.

NOTE: THE TINES LOCATED AGAINST THE GRILL SIDES ARE NOT REMOVABLE. HOWEVER, WEAR MAY BE COMPENSATED WITH ARC WELDING.

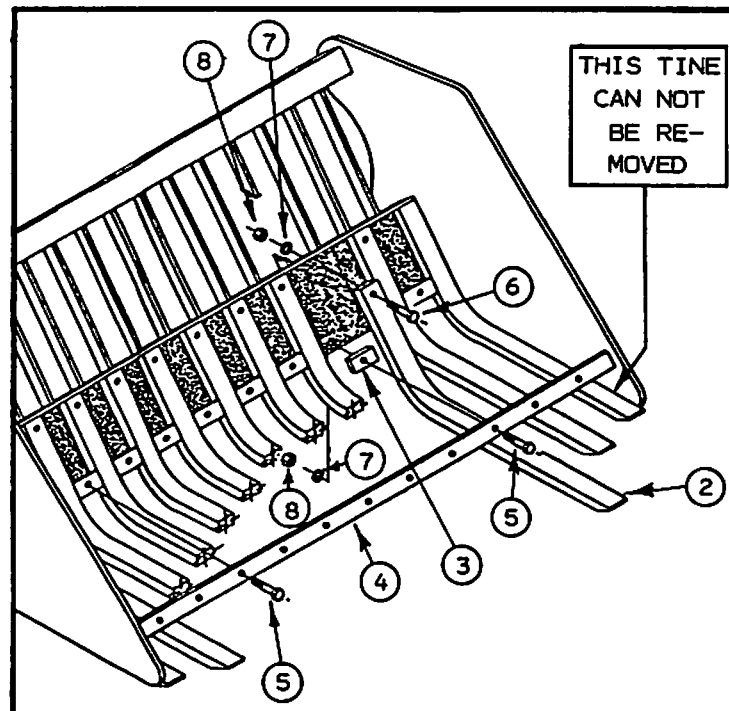

FIGURE # 13

ONCE THE REPLACEMENT GRILL TINES ARE IN PLACE SECURE EACH WITH A 5/8 X 2-1/2 IN. HEX BOLT (6), LOCK WASHER (7) AND HEX BOLT (8), BUT DO NOT TIGHTEN. INSTALL A TINE SPACER BLOCK (3) BETWEEN THE GRILL TINES. INSTALL THE GRILL TINE HOLDER BAR (4) AND SECURE WITH 5/8 X 3 IN. HEX BOLTS (5), LOCK WASHERS AND HEX NUTS AT EACH HOLE, MAKING SURE THAT EACH SPACER BLOCK WAS INSERTED BY THE CORRESPONDING HEX BOLT. TIGHTEN HEX BOLTS (5) FIRST TO 110 FT-LB. AND SECOND, HEX BOLTS (6) TO SAME TORQUE

NOTE: FREQUENTLY CHECK AND RETIGHTEN BOLTS TO SPECIFIED TORQUES SHOWN.

BOLT DIA. (IN.)	BOLT TORQUE (ft-lbs)			
	GRADE 5		GRADE 8	
	UNC	UNF	UNC	UNF
1/2	55	65	80	90
9/16	80	90	110	130
5/8	110	130	170	180
3/4	200	220	280	320
7/8	320	350	460	500
1	480	530	680	740

* TORQUES ARE FOR PLATED OR LUBRICATED THREADS.



WHOLEGOOD ITEMS ARE LISTED IN THIS PARTS MANUAL IDENTIFIED BY
BOXED PART NUMBERS AND ARE NOT SOLD AS PARTS.



DOTTED RECTANGLES DENOTE ITEMS THAT ARE NOT STOCKED AS PARTS.
USUALLY THESE ITEMS ARE CONTAINED IN A WHOLEGOOD BUNDLE.

FRAME AND HOPPER BOX

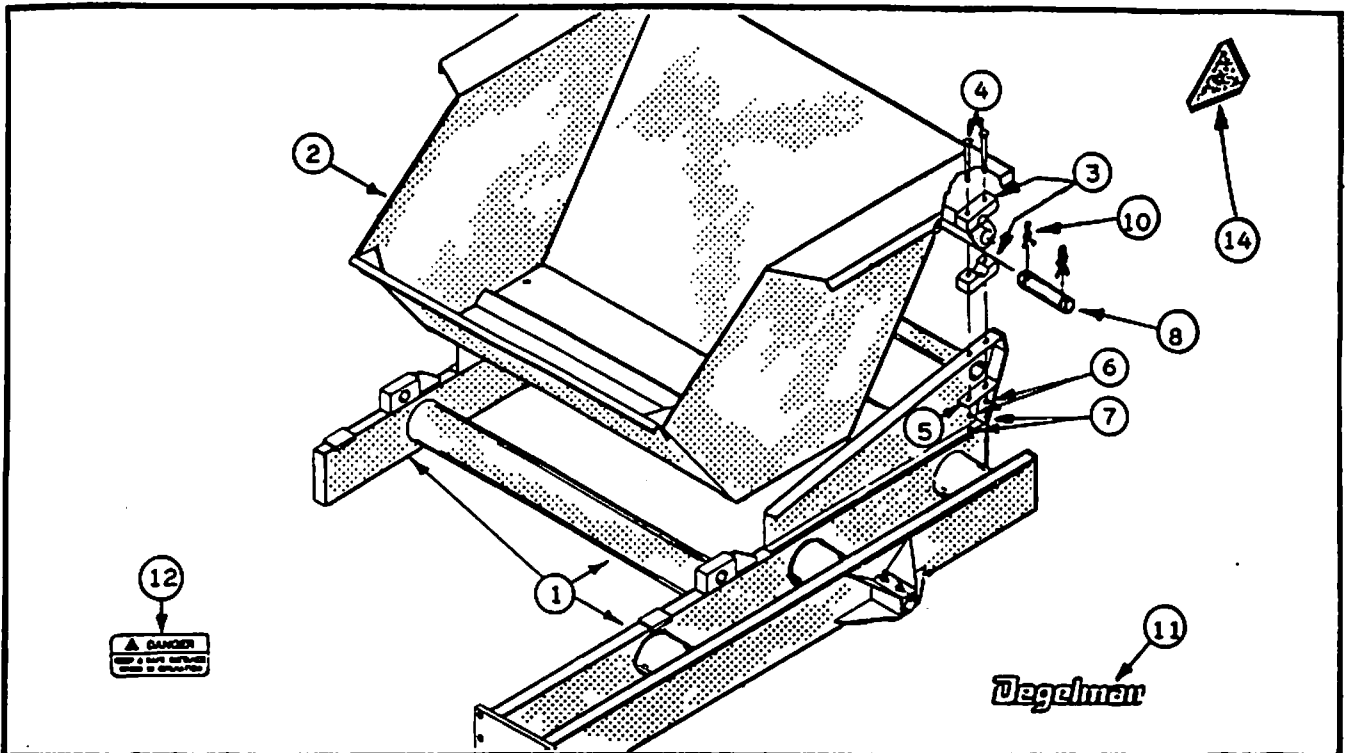

KEY NO.	PART NUMBER	PART DESCRIPTION	UNITS PER MACHINE	PIECES PER UNIT
1	203002	FRAME ASSEMBLY	1	
2	206000	HOPPER BOX ASSEMBLY	1	
3	110001	CASTING, BEARING HALF	4	
4	118060	BOLT, HEX 3/4 X 5 IN. - UNC - GR.2	4	
5	201280	STRAP, SUPPORT 1-1/2 X 6 IN.	2	
6	118509	WASHER, LOCK 3/4 IN.	4	
7	118410	NUT, HEX 3/4 IN. - UNC	4	
8	121945	PIN 25.4 X 125 MM(EFF)-PL-N/D	2	
10	118882	PIN, HAIR 3/16 X 2-3/4 IN.-PL-N/D	4	
11	142008	DECAL, 'DEGELMAN' - 6 X 26 IN.	1	
12	142109	DECAL, 'DANGER' - 3-1/2 X 9 IN.	3	
14	142156	DECAL, SLOW MOVING VEHICLE SIGN	1	

WHEEL, HUB & AXLE ASSEMBLY SECTION

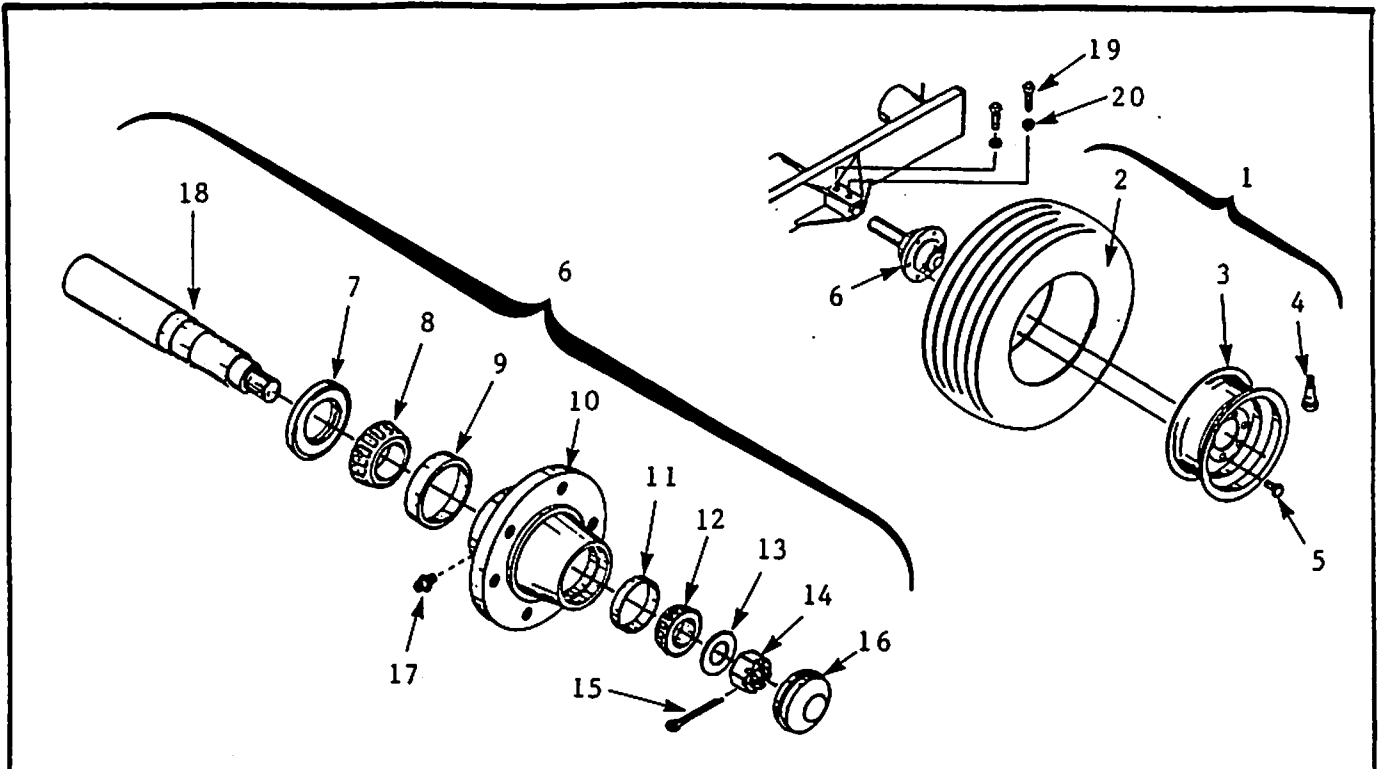

KEY NO.	PART NUMBER	PART DESCRIPTION	UNITS PER MACHINE	PIECES PER UNIT
1	131329	Wheel Assy 12.5Lx15-8 Ply-3/4 in. Pos Offset	a/r	1
2	127007	Tire 12.L x 15-8 Ply Tubeless		1
3	131328	Rim, Wheel 15x10 LBH-6 Bolt 3/4 in. Pos Offset		1
4	127006	Valve Stem - TR415		1
5	118313	Bolt, Wheel 9/16 x 1 1/16 in. UNF,Gr5,Plated		6
6	131017	Hub/Spindle Assy - H618 - 2 x 12 in. Spindle	a/r	1
7	131026	Dust Seal CR#20140 - 2.000 in. ID		1
8	131022	Cone, Bearing #25580 - 1.750 in. ID		1
9	131023	Cup, Bearing #25520 - 3.265 in. OD		1
10	131013	Hub H618G c/w Cups #9 & 11		1
11	131025	Cup, Bearing LM48510 - 2.563 in. OD		1
12	131024	Cone, Bearing LM48548 - 1.375 in. OD		1
13	131020	Washer, Flat 1 in. SAE		1
14	118423	Nut, Slotted 1 in. UNS, Gr5		1
15	118835	Pin, Cotter 3/16 x 1 1/2 in.		1
16	131016	Cap, Hub H618 & H619		1
17	118335	Grease Fitting 1/4 - 28 AMNF-Straight		1
18	131080	Spindle - S618 - 2 x 12 in. c/w Nut #14		1
19	118251	Setscrew, Sq Head 5/8 x 1 1/2 in. UNC	2	
20	118416	Nut, Jam 5/8 in. UNC, Gr2, Plated	2	

HITCH POLE

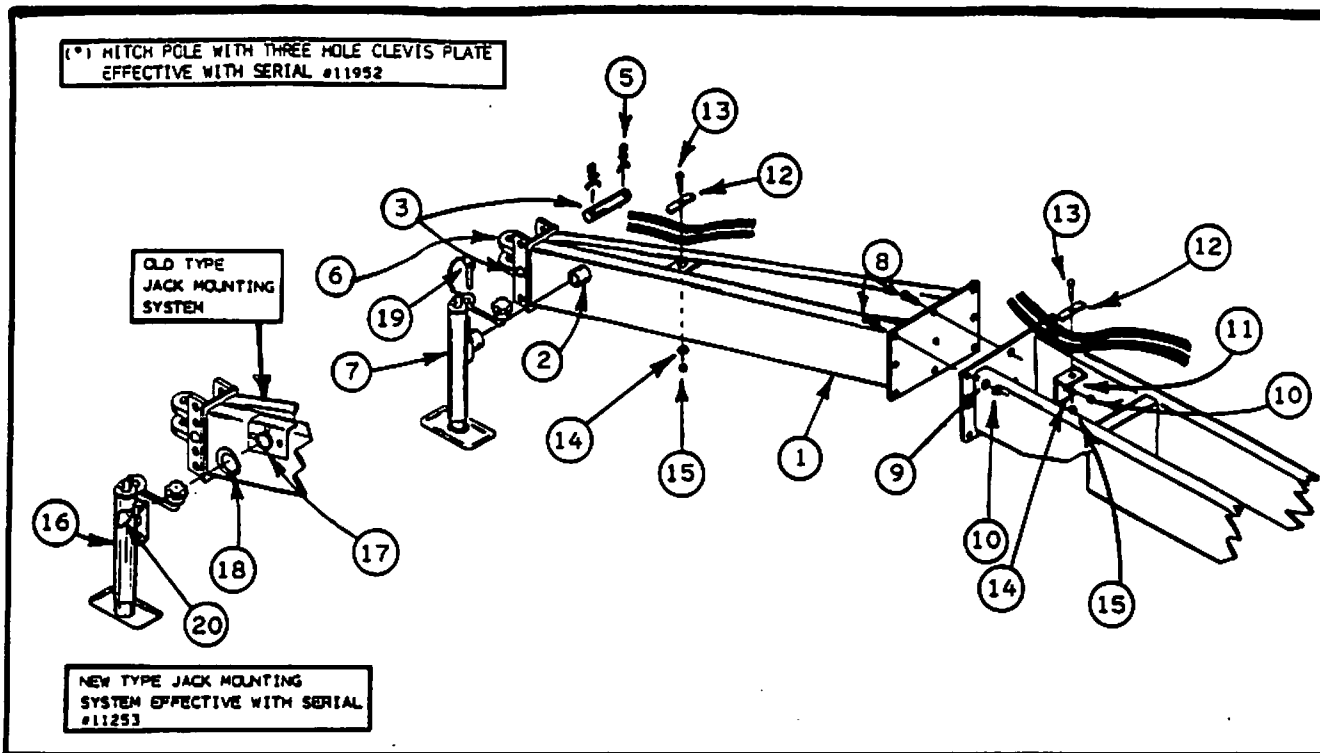

KEY NO.	PART NUMBER	PART DESCRIPTION	UNITS PER MACHINE	PIECES PER UNIT
	224100	HITCH POLE ASSEMBLY,	1	
1	(*)224110	(AS SHIPPED WITH NEW MACHINES) CONSISTS OF: HITCH POLE, (REPLACES OLD STYLE HITCH POLE #223000)		1
2		C/W: 132008 NEW TYPE JACK MOUNTING BRACKET		1
3	121944	PIN 25.4 X 110 MM(EFF)-PL-N/D		1
5	118882	PIN, HAIR 3/16 X 2-3/4 IN.-PL-N/D		2
6	110002	CASTING, CLEVIS HITCH		1
7	132004	JACK ASSEMBLY, TOP WIND NEW STYLE	1	
8	118023	BOLT, HEX 5/8 X 1-1/2 IN. - UNC		
9	118508	WASHER, LOCK 5/8 IN.		
10	118407	NUT, HEX 5/8 IN. - UNC		
11	201043	BRACKET, HOSE SUPPORT	1	
12	650256	CLIP, HOSE BRACKET	2	
13	118144	BOLT, HEX - 5/16 X 1-1/2 IN. - UNC - GR. 5	2	
14	118511	WASHER, FLAT - 3/8 IN.	1	
15	118427	NUT, HEX - 5/16 IN. - UNC	2	
16	132002	JACK ASSEMBLY, TOP WIND OLD STYLE	1	
17	132007	PLATE, JACK MOUNTING OLD TYPE		1
18	132006	RING, JACK RETAINING FOR OLD TYPE JACK ONLY		1
19	118879	PIN, HITCH JACK 9/16 IN. DIA.		1
20	118878	PIN, HITCH JACK 1/2 IN. DIA		1

HYDRAULIC LIFT MECHANISM

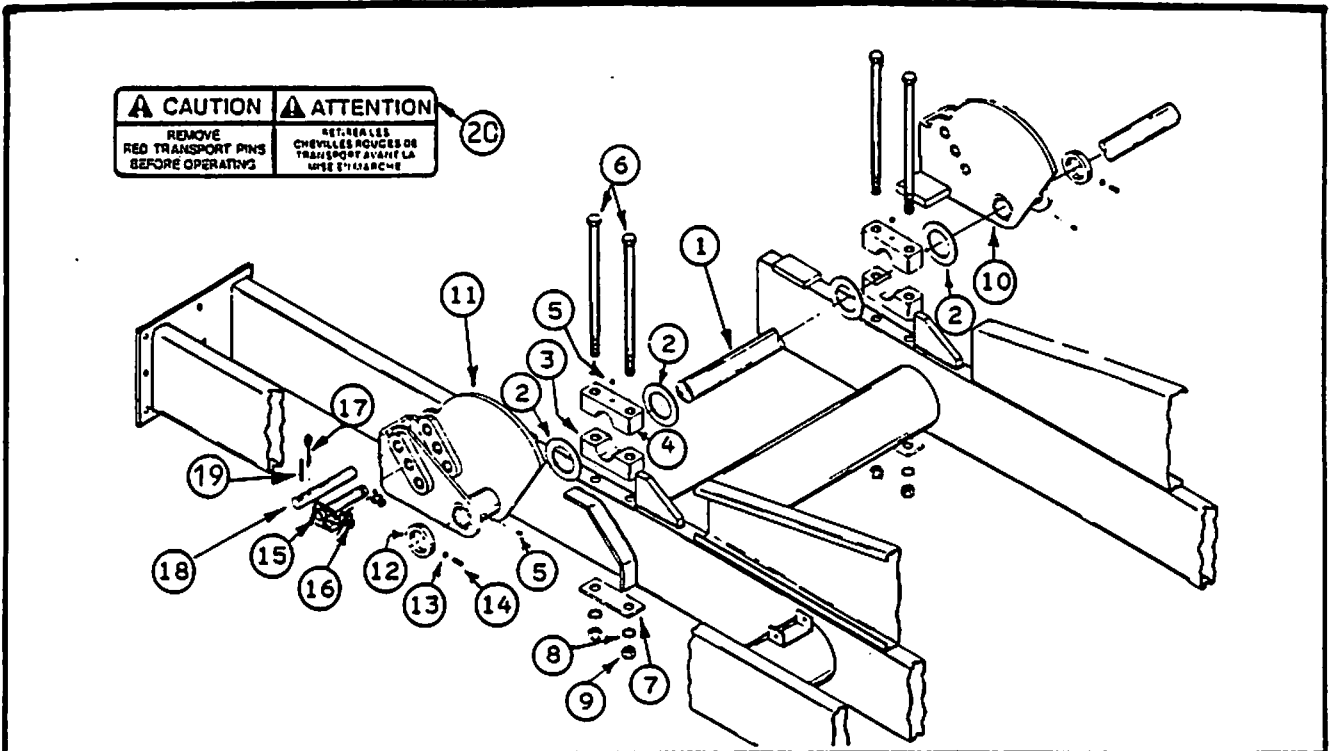

KEY NO.	PART NUMBER	PART DESCRIPTION	UNITS PER MACHINE	PIECES PER UNIT
1	208130	SHAFT	1	
2	118523	WASHER, SPACER	4	
3	110001	CASTING, BEARING HALF LOWER	2	
4	110020	CASTING, BEARING HALF UPPER - C/W:	2	
5	118336	FITTING, GREASE - 1/4 - 28 NPT		1
6	118071	BOLT, HEX - 3/4 X 14 IN. - UNC - GR 2	4	
7	203110	STRAP, SUPPORT - 2 X 6 IN.	2	
8	118509	WASHER, LOCK - 3/4 IN.	4	
9	118410	NUT, HEX - 3/4 IN. - UNC	4	
10	219000	ARM, HYDRAULIC LIFT RH - C/W:	1	
5	118336	FITTING, GREASE - 1/4 - 28 NPT		1
11	220000	ARM, HYDRAULIC LIFT LH - C/W:	1	
5	118336	FITTING, GREASE - 1/4 - 28 NPT		1
12	208120	COLLAR, LOCKING	2	
13	118415	NUT, HEX JAM - 3/8 IN. - UNC	2	
14	118250	SETScrew, SQ. HEAD - 3/8 X 1 IN. - UNC	2	
15	121945 Z20011	PIN, 25.4 X 128 MM (EFF)-PL-N/D	2	
16	118882	PIN, HAIR 3/16 X 2-3/4 IN.-PL-N/D	2	
17	118838	PIN, COTTER - 1/4 X 1-1/2 IN.	2	
18	118808	PIN, TRANSPORT - 6-3/4 IN. - C/W:	2	
19	118843	- PIN, ROLL - 1/4 X 1-1/2 IN.		1
20	142256	DECAL, CAUTION - REMOVE/RETIRER	2	

PICKING GRILL ASSEMBLY

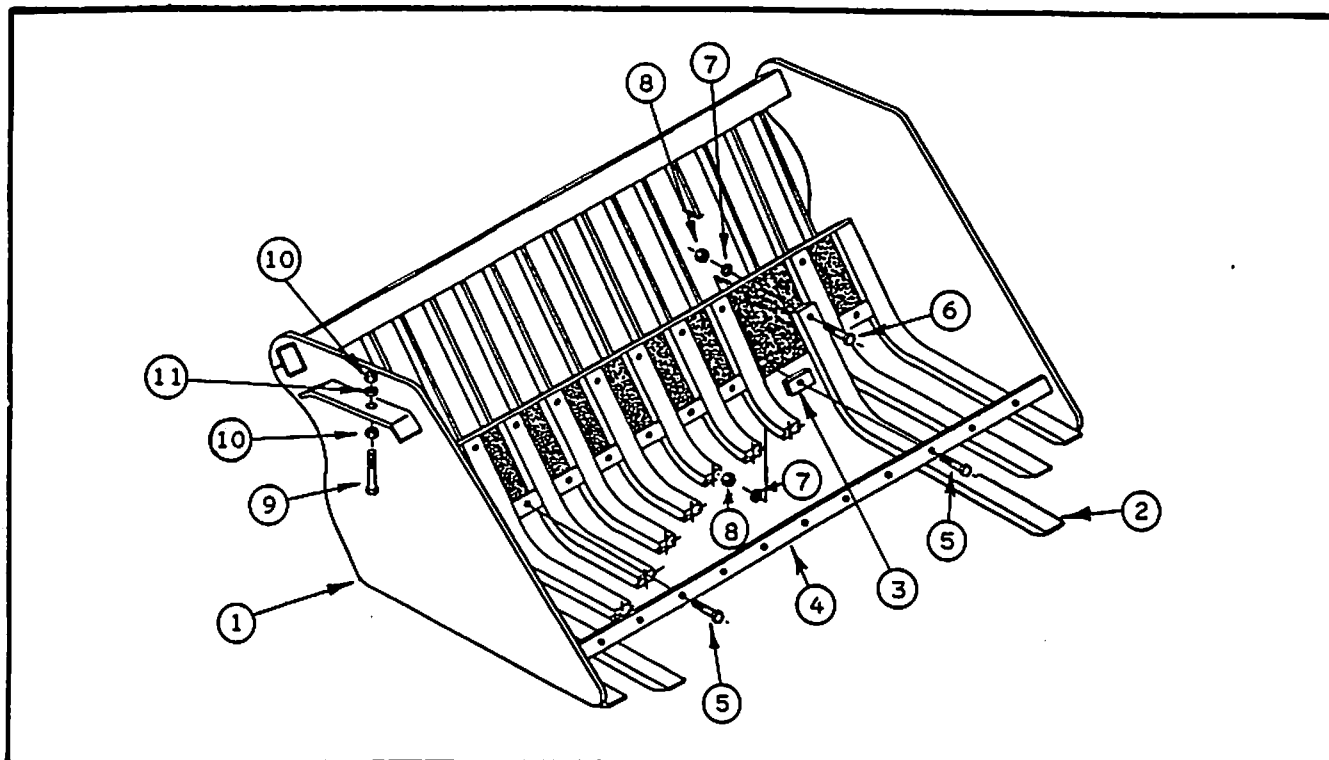

KEY NO.	PART NUMBER	PART DESCRIPTION	UNITS PER MACHINE	PIECES PER UNIT
	208000	GRILL ASSEMBLY - COMPLETE AS SHIPPED WITH NEW MACHINES - CONSISTS OF:	1	
1	208002	GRILL ASSEMBLY - LESS TINES AND HOLD DOWNS		1
2	137002	TINE, GRILL - REPLACEABLE		10
3	208150	BLOCK, GRILL TINE SPACER		11
4	208140	BAR, GRILL TINE HOLDER		1
5	118030	BOLT, HEX 5/8 X 3 IN. - UNC - GR. 5		11
6	118028	BOLT, HEX 5/8 X 2-1/2 IN. - UNC - GR. 5		10
7	118508	WASHER, LOCK 5/8 IN.		21
8	118407	NUT, HEX 5/8 IN. - UNC		21
9	208110	ADJUSTER 1 X 4-1/2 IN.		2
10	118412	NUT, HEX 1 IN. - UNC		4
11	118510	WASHER, LOCK 1 IN.		2

HYDRAULIC SYSTEM

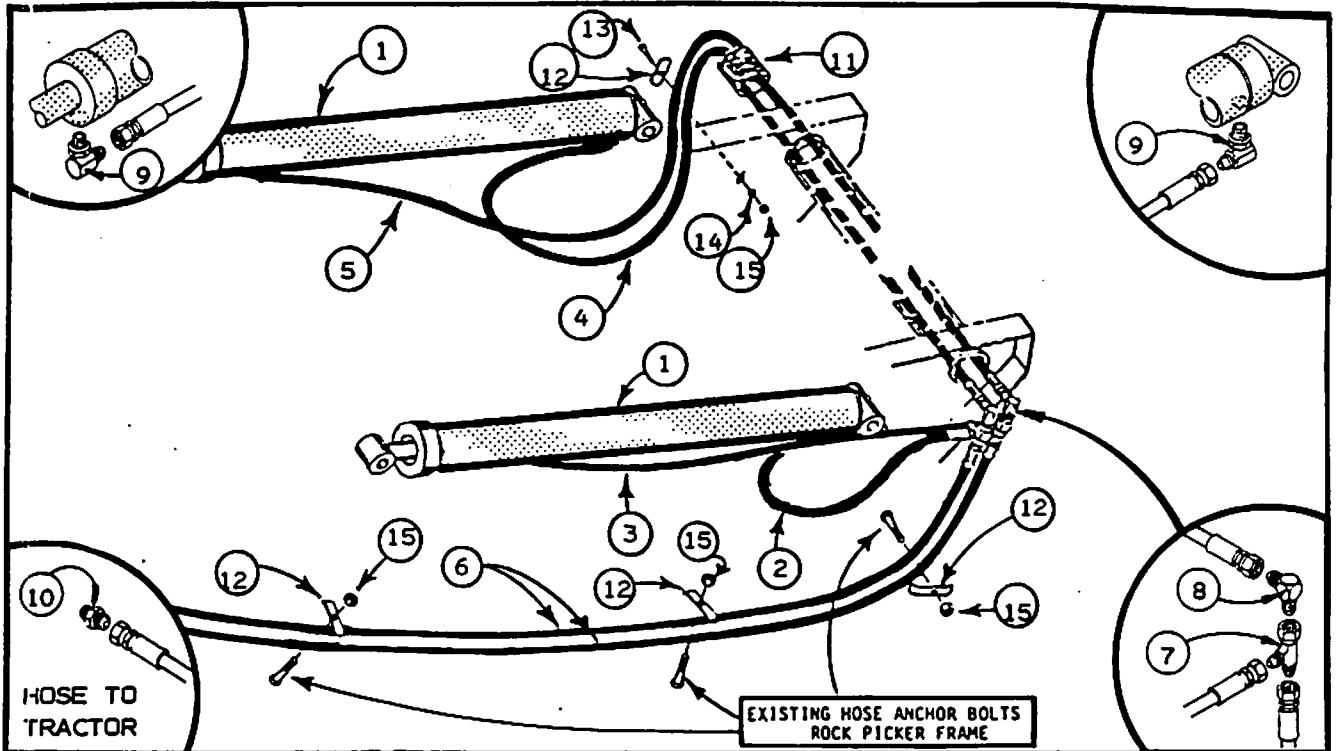

KEY NO.	PART NUMBER	PART DESCRIPTION	UNITS PER MACHINE	PIECES PER UNIT
1	121709	HYDRAULIC CYLINDER 2-1/2 X 31 IN.	2	
2	126545	HOSE 3/8 X 29 2WB - 3/4 JIC(F-SW)	1	
3	126547	HOSE 3/8 X 42 2WB - 3/4 JIC(F-SW)	1	
4	126551	HOSE 3/8 X 96 2WB - 3/4 JIC(F-SW)	1	
5	126512	HOSE 3/8 X 106 2WB - 3/4 JIC(F-SW)	1	
6	126553	HOSE 3/8 X 216 2WB - 3/4 JIC(F-SW)	2	
7	141503	TEE, 3/4 JIC(F-SW) X 3/4 JIC(M) X 3/4 JIC(M)	2	
8	141513	ELBOW, 90 DEG. 3/4 JIC(M) X 3/4 JIC(M)	2	
9	141504	ELBOW, 90 DEG. 3/4 JIC(M) X 3/4 ORB(M)	4	
10	141514	NIPPLE 1/2 NPT(M) X 3/4 JIC(M)	2	
11	133010	GROMMET, FOAM RUBBER 1-3/8 ID X 3/8 WALL	1	
12	650256	CLIP, HOSE	4	
13	118144	BOLT, HEX 5/16 X 2-1/2 IN. UNC, GR 5	1	
14	118530	WASHER, LOCK 5/16 IN.	1	
15	118427	NUT, HEX 5/16 IN. UNC	4	

HYDRAULIC CYLINDER 2-1/2 x 31 .DIL

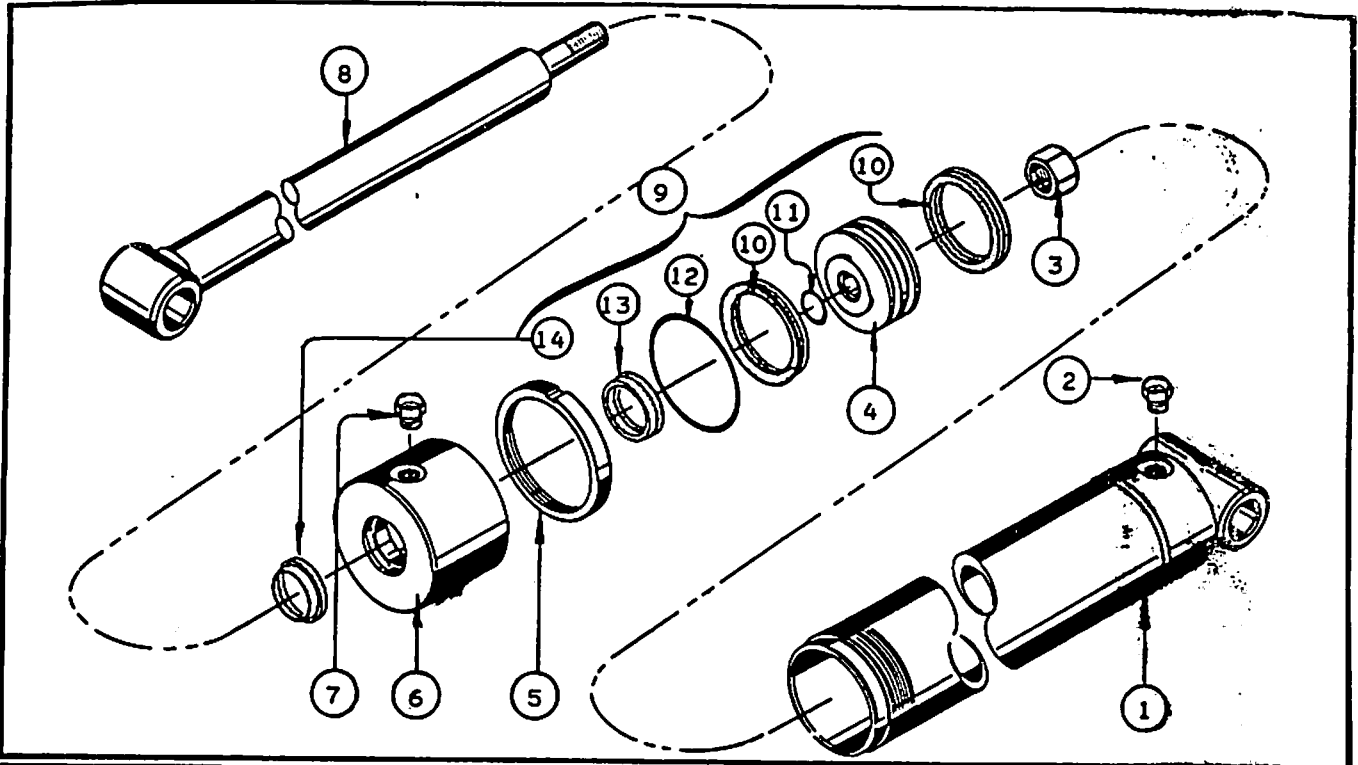

KEY NO.	PART NUMBER	PART DESCRIPTION	UNITS PER MACHINE	PIECES PER UNIT
	121709	Hydraulic Cylinder Assy. - DIL - 2 1/2 x 31 Complete - 3/4 - 16 ORB Ports Consists of:		
1	121711	- Barrel Assy. - 2 1/2 in. I.D. - includes:	1	
2		One - 121326 Port Plug 3/4 - 16 ORB		
3	118441	- Nut, Lock - 7/8 in. - UNF	1	
4	121664	- Piston, 2 1/2 in. O.D.	1	
5	121741	- Lock Ring, 2 1/2 in. Cylinder	1	
6	121713	- Cap, Open End - Assy. - includes:	1	
7		One - 121326 Port Plug 3/4 - 16 ORB		
8	121648	- Rod Assy. - 1 1/2 in. O.D.	1	
9	121710	- Seal Kit - Consists of:	1	
10		Two - Piston Outer U-Cup		
11		One - Piston Inner O-Ring		
12		One - Cap Inner O-Ring		
13		One - Cap Inner U-Cup		
14		One - Rod Wiper Seal		
		NOTE: Complete rebuilt Hydraulic Cylinders may be available.		

DegeIman **INDUSTRIES LTD.**

**272 Industrial Drive, Box 830
Regina, Sask. Canada S4P 3B1
306 543-4447 543-2140 fx
1-800-667-3545
degeIman@degeIman.com**

www.degeIman.com