



## **TABLE OF CONTENTS**

INTRODUCTION .....	1
WARRANTY INFORMATION .....	1
SAFETY PRECAUTIONS .....	2
MACHINE MAINTENANCE & LUBRICATION .....	2
WHEEL & TIRE INFORMATION .....	3
WHEEL EXTENSION .....	3
HYDRAULIC HOOK UP .....	3
HIGHWAY TRAVEL .....	4,5
REAR HITCH ADJUSTMENT .....	6
ADJUSTING RAKE WHEEL ARM SPRING TENSION .....	7
TINE REPLACEMENT .....	8
SPECIFICATIONS .....	9

## **SPECIFICATIONS**

Overall Length ..... 32'

Overall Width ..... 7.5'

Overall Height ..... 5.4'

### **Overall Weight**

12 Wheel .....3616 lbs.

14 Wheel ..... 4115 lbs.

Tire Size ..... P215/70R15

Tire Pressure ..... 35 psi.

### **Torque Settings (Wheel Bolts)**

9/16"	Dry 120 Lb.
1/2"	Dry 90 Lb.
3/4"	Dry 300 Lb.

## TINE REPLACEMENT

If a tine on one of the rake wheels needs to be replaced, the following procedure can be used:

- The bolt on the back of the rake wheel that corresponds to that tine should be loosened and removed completely.
  - Slide the tine out of the hole in the outer ring.
- Insert the replacement tine in the same direction as the other tines on the rake wheel.
- Then insert the bolt back in to the wind guard and tighten the nut.

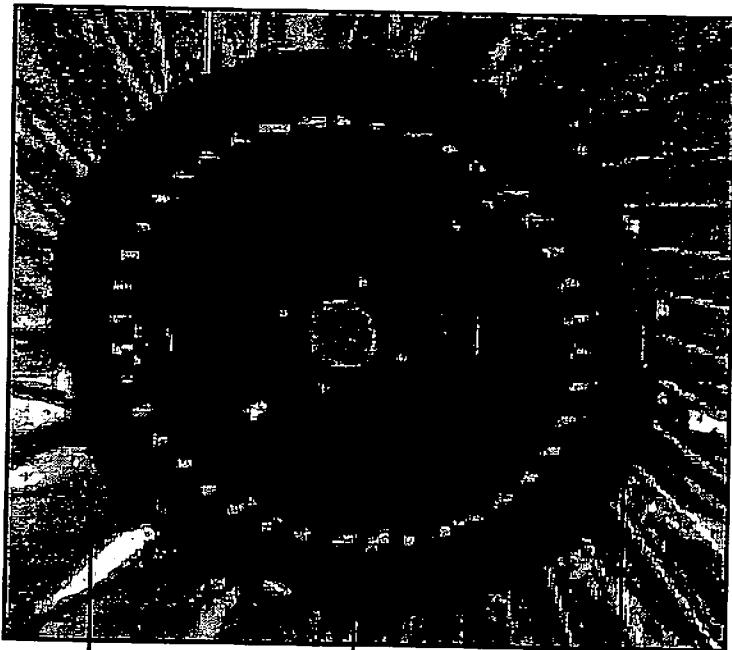

Tooth

Bolts

Wind Guard

## INTRODUCTION

Thank you for purchasing your new **Bale King V-Rake**. With the proper operation and service as outlined in this manual, this V-Rake will provide you with years of trouble free operation.

## WARRANTY INFORMATION

Bridgeview Manufacturing Inc. warrants the **Bale King VR1214 V-Rake** to its original owner for a period of one year from the date of purchase according to the following provisions:

- Warranty covers **defects** in material and workmanship.
- Warranty **does not** cover damage to the machine and its components if the operator does not follow the operating instructions in the user manual.
- Warranty **does not** cover normal wear and tear.
- Warranty will be **VOID** and Bridgeview Manufacturing Inc. is not liable in any way if the Bale King VR1214 V-Rake is used for any purpose other than its intended use.
- Tire warranty is covered by the **Tire Manufacturer**.

All warranty and service **must** be handled through an authorized Bale King dealer. Any repairs after the warranty period are the owner's responsibility. Any **overtime** requested by the owner to have the machine repaired during the warranty period will be the owners responsibility. Warranty is at the dealership and **no** travel time will be reimbursed. Freight costs associated with warranty repairs will not be reimbursed. Warranty does not cover down time. Warranty will be **VOID** if any component is altered or modified in any way, unless written permission is given by Bridgeview Manufacturing Inc.

Bridgeview Manufacturing Inc. reserves the right to make changes or improvements at any time without notice or obligation.

## **SAFETY PRECAUTIONS**

The following safety precautions **MUST** be followed to ensure the safe operation of the Bale King V-Rake:

1. This trailed machine was designed and intended for on-farm use only. Tow at speeds not to exceed 20 MPH. Slow down for hills, curves, rough area, and in advance of braking to prevent loss of control and possible injury or death.
2. **Always** turn off the tractor when leaving the operating platform.
3. **Always** use a safety chain and the transport links when towing the V-Rake on the highway.
4. Unless operating tractor, **stand clear** of the rake when in operation.
5. **Do not** stand inside the rake while it is being opened or closed.

## **MACHINE MAINTENANCE AND LUBRICATION**

General maintenance of your V-Rake should be done on a regular basis. This includes checking all bolts to ensure they are tight, making sure all grease zerks are accepting grease and ensuring that all moving parts are functioning correctly.

Your Bale King V-Rake is equipped with a number of grease zerks. It is important that these locations are lubricated according to the following maintenance schedule:

- Wheel hubs for the tires and rake wheels should be greased every 200 hours of use.
- Knuckles, scissor arm pins, lift arms and any remaining grease zerks should be greased every 10 hours use.

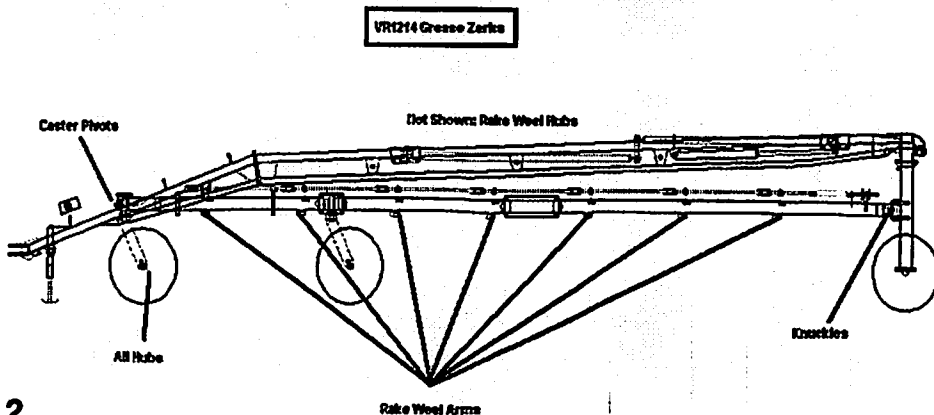

## **ADJUSTING RAKE WHEEL ARM SPRING TENSION**

The tension in the spring arms comes pre-set. If the tension in the spring arms needs to be adjusted there are a number of ways to accomplish this. The first is by moving the threaded rod adjusters.

The threaded rod adjusters are located at the rear end of each rake arm and are directly attached to the lift rod cylinder. By adjusting the bolts attached to the rod adjusters the tension in all the springs of that rake arm are adjusted evenly.

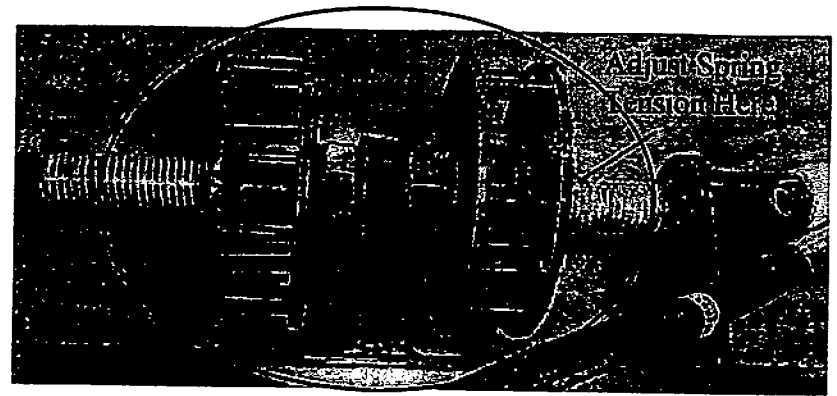

If the spring tension in only one spring needs to be adjusted then the adjustment can be done on the individual spring. There are two nuts near the end of the spring that allow the spring to be loosened or tightened.

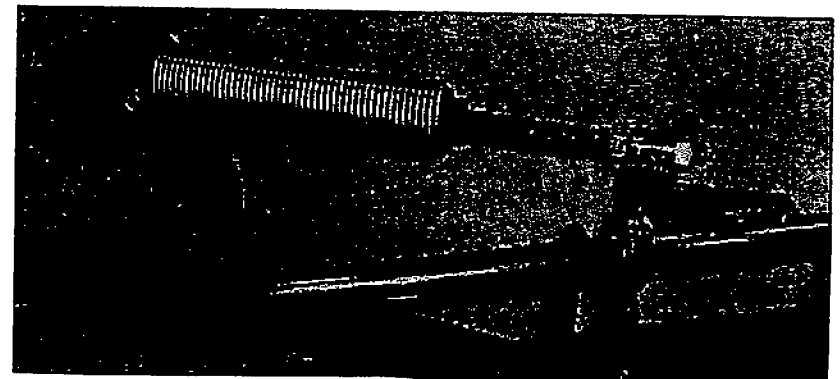

## **REAR HITCH ADJUSTMENT**

The rear hitch of the V-Rake is designed to be adjustable. Widening the rear hitch will space the rake wheels further apart, creating a wider windrow. Pulling the rear hitch closer together will also pull the rake wheels closer together, and make a tighter swath.

To adjust the rear hitch width make sure the hitch is clear of obstructions. The clamp plates on each side of the rear hitch must be loosened, but not detached. By turning the rear jack the rear hitch can be opened or closed. Both sides of the rear hitch open simultaneously. Have someone drive forward slowly while turning the rear jack. This will make it easier for the hitch to spread. Once the desired width is reached the clamp plates can be tightened up and the rake is ready for use.

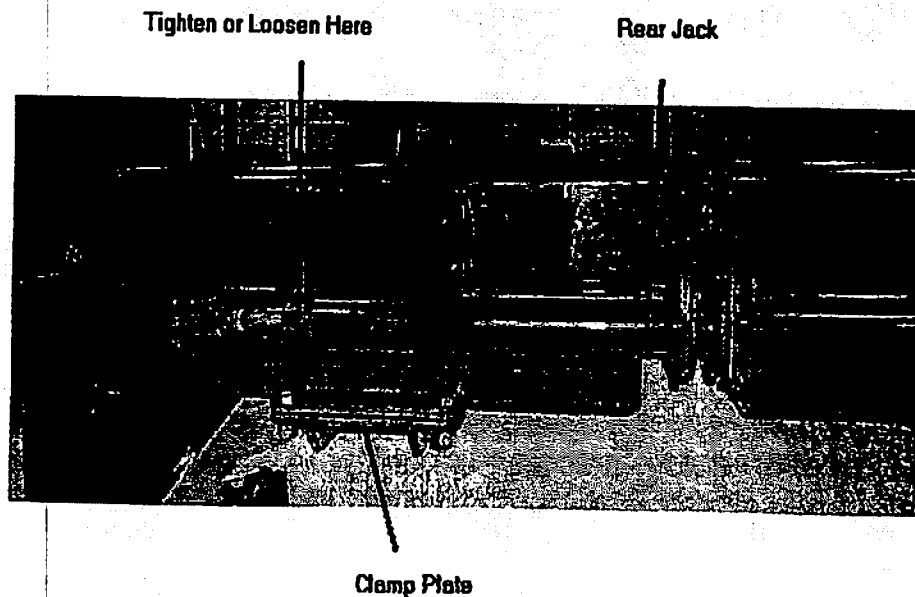

## **WHEEL AND TIRE INFORMATION**

The proper tire pressure for the Bale King V-Rake is 35 psi. Proper tire inflation will help alleviate a puncture problem when pulling and operating the machine in rough terrain.

The optimum tire size is P215/70R15.

**NOTE:** Check and tighten wheel bolts on a regular basis to ensure that bolts are tight!

Warranty does not cover damaged rims and hubs due to loose wheel bolts.

Tire warranty is covered by the tire manufacturer.

## **WHEEL EXTENSION**

The 12 Wheel Rake can be fitted with an extension kit. This Kit extends the length of the rake arms, adding one rake wheel to each side, making the rake a 14 wheel rake. The extension kit also adds an extra set of caster wheels to the rake arms. This option increases the area covered by the rake and can be purchased as a separate kit to the 12 wheel rake.

## **HYDRAULIC HOOK UP**

There are four hydraulic hoses to be connected to the tractor. All four hoses run out of the gooseneck of the rake, near the hitch. The hose marked with green adjusts the main cylinder, used to open and close the rake arms. The hose marked with yellow adjusts the lift arm cylinders used to raise and lower the rake wheels. These hoses should be connected to the most convenient hydraulic hook ups on the tractor.

## HIGHWAY TRAVEL

When transporting your V-Rake on the highway there are a number of safety precautions that must be taken to ensure safe travel.

First is to insert the cylinder safety locks. The lift arm cylinders (located on the left and right rake arms) should be fitted with cylinder safety locks. To insert the safety locks, raise the rake wheels to their highest position, then insert the safety lock.

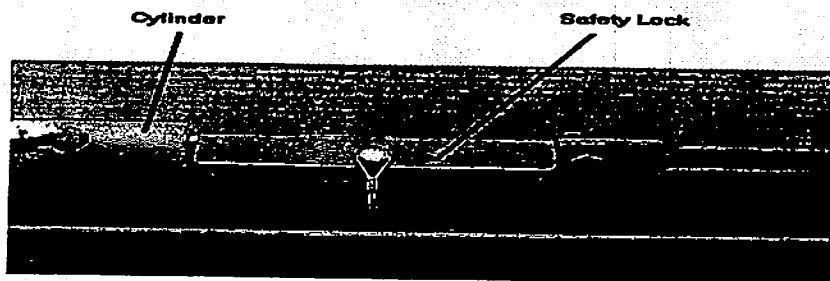

The transport links must also be installed. These links attach to the outside of the main frame and the inside of the rake arms. The links must be adjusted so that they are evenly spaced. Ensure that the links have the proper pins and cotter pins in place.

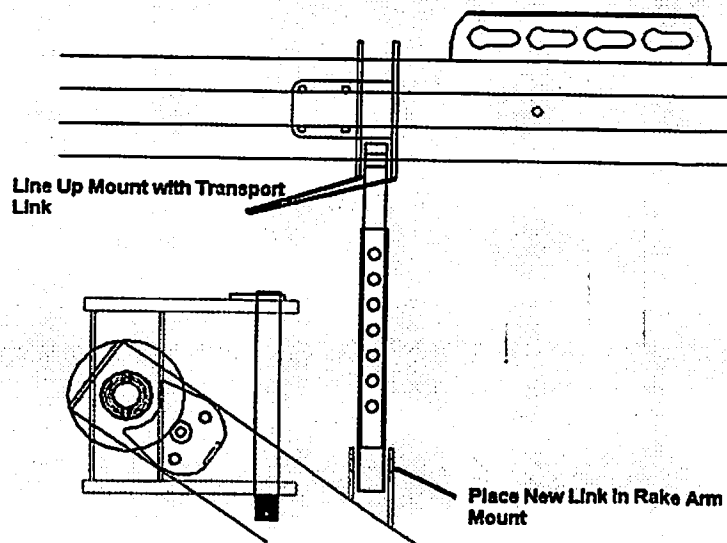

Make sure that you have attached a safety chain to the hitch through the safety chain hole.

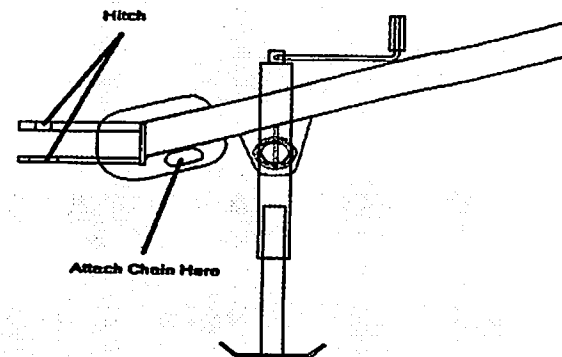

Align the road wheels and tighten the brake springs for the front casters. The caster wheels will whip if the brakes are not sufficiently tight!

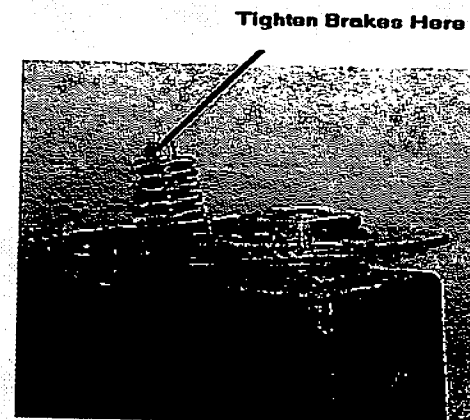

Ensure that all of the tires are at the correct pressure and that all wheel bolts are secured.