



## FEATURES & SPECIFICATIONS

## TABLE OF CONTENTS

Introduction	2
Warranty Information	3
Safety Precautions	4
PTO Safety Labels	5-6
PTO Use & Maintenance	7-8
PTO Assembly and Disassembly	9
Machine & PTO Lubrication	10
Optional Fine Chop Kit	11
Shear bolt Clutch PTO Shaft	12
Gearbox Maintenance	13
Tire Inflation & Ply Rating	13
PTO Holder and PTO Hookup	14
Wheel Hub & Twine Guard	15
Loading Bales	16
Horsepower Rating & Twine Guard	17
Implement Tongue	18
Hydraulic Hook up	18
Hoop Grate Adjustment	19
Deflectors	20
Rotor Operation	21
Rotation of Bales	21
Twine Removal	22
Flail and Bushing Replacement	23
Bale Tine Installation	23
Cylinder Maintenance	24
Trouble Shooting Guide	25
Features and Specifications	26

Heavy Duty Reinforced Frame and Axle Assembly	
Main Frame	4"x 6"
Frame Width	44.5"
Heavy Duty Square Jack	Mounted Inside Frame
Large Bale Chamber	80"
Spring Lock Lever on Grate and Deflector Adjusters	
Discharge Opening	10 1/2"x 75"
Bottom Deflector	8"x 80"
Heavy Duty Bale Fork Frame	3"x6"
Bale Fork Width (on centers)	49"
Small Bale Tines Optional	
Dual Hydraulic Lift Cylinders	2 1/2"x 20"
Tread Width (on centers)	72"
Tire Size.	
Standard	11L x 15-8ply
Optional	31-13.5x15-8ply
Overall Weight	3900 lbs.
Overall Height	114"
Overall Length..	w/o tines 160"
Adjustable Hitch	
Rotor Extended Tip Diameter	26 1/2"
Flail Tip Speed at 1000 RPM	7000 FPM
Oil Impregnated Bushing in Flails	
Number Of Flails	30
Flail Size	3/4 x 1 1/2 x 8 5/8"
3" Stub Shaft Rotor	1 15/16" Bearings
Disc Type Twine Guard	
PTO Shaft	CV Bondioli
PTO Holder Removable	1 x 1 Tubing
Minimum Horse Power Requirements	75 HP
Shear Bolt	Bondioli 10mm x 60mm GR 8.8

<b>PROBLEM</b>	<b>POSSIBLE CAUSE</b>	<b>REMEDY</b>
Excessive main shear bolt breakage	Engaging PTO at high engine speed or too quickly	Idle tractor to engage PTO then bring up to full operating speed /feather PTO lever into position.
	Excessive twine wrapped on rotor causing flail movement to be restricted	Cut twine off rotor
	Broken flails causing rotor to be out of balance	Replace broken flails(in pairs opposite each other)
	Overloading rotor	<ul style="list-style-type: none"> <li>☞ Set hoops to less aggressive position</li> <li>☞ Slow rotation of bale</li> <li>☞ Change direction of bale rotation</li> </ul>
	Incorrect Shear bolt used	Use correct Shear bolt
	Operating Machine at less than 1000 PTO RPM	Operate machine at rated 1000 PTO RPM
Excessive vibration while processing bales	Excessive twine wrapped around rotor restricting full flail movement	Remove twine from rotor
		Replace broken or missing flails(in pairs opposite each other)
	Hoops set in a position too aggressive for the type of material being processed causing an overload	Adjust hoops to a less aggressive position
	Rotating bale too fast causing rotor overload	Slow rotation of bale
	Operating machine at less than 1000 PTO speed	Operate machine at rated 1000 PTO speed
	Rotor bearing failure	Replace failed parts
Beaters stopping	Excessive loose material in tub causing beater to jam	Reverse direction of bale rotation Turn bale more slowly
A single beater stopping	Mechanical flow valve not functioning correctly	Contact your dealer for repairs
	Coupler between motor & beater broken	Replace broken parts

Thank you for purchasing your new **Bale King** bale processor.

With the proper operation and service as outlined in this manual, the Bale King will provide you with years of trouble free operation.

**The Serial Number is located on upper left hand front corner of the tub.**

**VORTEX 3100** to its original owner for a period of two years from the date of purchase according to the following provisions:

**Normal Farm Use:**

1st year warranty covers parts and labour

**EXCEPTION : Flails** are considered a wearing part and covered for **breakage for 60 days** from purchase date

2nd year warranty covers parts **only**.

**Commerical, Government, or Rental Use:**

1 year warranty covers parts and labour **Exception: Flails** are considered a wearing part and are covered against **breakage for 60 days** from date of purchase.

- Warranty covers **defects** in material and workmanship.
- Warranty **does not** cover damage to the machine and its components if the operator does not follow the operating instructions in the operator's manual.
- Warranty **does not** cover normal wear and tear.
- Warranty will be **VOID** and Bridgeview Manufacturing Inc. is not liable in any way if the Bale King Vortex 3100 is used for any purpose other than it's intended use.
- Tire Warranty is covered by the **Tire Manufacturer**.
- 

All warranty service must be handled through an authorized Bale King dealer. Any repairs after the warranty period are the owner's responsibility. Any **Overtime** requested by the owner to have the machine repaired during the warranty period will be the owner's responsibility. Warranty is at the dealership and **no** travel time will be reimbursed. Freight costs associated with warranty repairs are not reimbursable. Warranty does not cover downtime. Warranty will be **VOID** if any component is altered or modified in any way, unless written permission is given by Bridgeview Manufacturing.

Bridgeview Manufacturing Inc. reserves the right to make changes or improvements at any time without notice or obligation.

The following safety precautions **MUST** be followed to ensure safe operation of the Bale King Bale Processor.

3

## CYLINDER MAINTENANCE

The hydraulic cylinders are easily removed for repair or maintenance simply by:

- 1) Lowering the fork to the down position and unhooking the hydraulic lines.

**NOTE: Be sure there is no pressure on the lines and mark the lines as to their placement so there is no confusion when re-installing the cylinders.**

- 2) Removing the cotter pin closest to the frame of the machine and sliding the cylinder pins out.

- 3) To re-install, reverse the removal procedure.

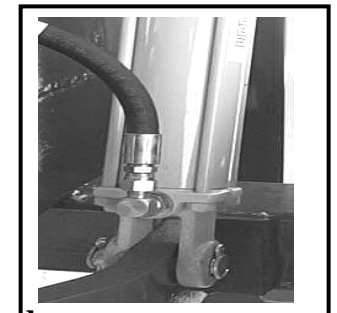

**NOTE: Always cover exposed cylinder shafts with grease to avoid rusting on shafts if unit is not used for extended periods of time. Rusted cylinder shafts are not covered by warranty**

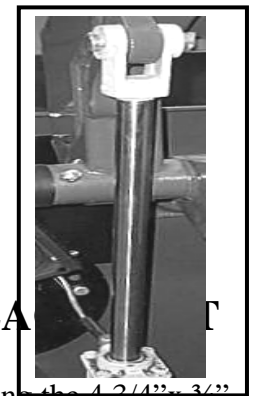

## FLAIL AND BUSHING REPLACEMENT

Flail replacement is accomplished by removing the 4 3/4" x 3/4" bolt holding the flail to the rotor.

The flail is then lifted away from the rotor. The bushing can now be removed by using slight pressure to push it out of the flail. Inspect the bolt, bushing, and the flail for wear. If excessive, replace with new parts.

Bridgeview Manufacturing Inc. recommends when changing flails to **change in pairs** (opposite each other).

Processing bales with broken flails causes the rotor to be out of balance and excessive vibration may cause machine deterioration.

**WARNING:**

**Do not walk or stand in front of the discharge chute while processing. Never direct discharge chute at cattle while processing.**

### 3 X 3 BALE TINE INSTALLATION

To install the 3 x 3 bale tine, remove the cotter key on the hinge pin at the bottom of the main fork frame.

Slide the tine into the slot at the bottom of the forks, align holes and insert the hinge pin. Install the cotter key in the pin and spread the cotter key to ensure the hinge does not accidentally fall out.



### SAFETY PRECAUTIONS

- 1) **ALWAYS** turn off the tractor when leaving the operating

platform.

- 2) **DO NOT** stand in front of the discharge chute while the machine is running.
- 3) **DO NOT** walk or move under the bale forks when they are in the upward position.
- 4) **DO NOT** enter the machine while in operation.
- 5) **DO NOT** clean machine while in operation.
- 6) **DO NOT** stick any device into the machine to clear debris while the machine is in operation.
- 7) **ALWAYS** turn off the machine when cleaning the machine, removing twines, or hooking/unhooking the machine
- 8) **ALWAYS** use safety chain tow ring located directly behind the hitch on the underside of the frame when towing the machine on the highway.
- 9) **DO NOT** operate if any part of the pto safety shielding is neither missing or is not secured.

### PTO SAFETY LABELS

The operator must obey all safety labels and must maintain the proper shielding. A high percentage of drive-line injuries occur when safety shielding is missing or not functioning properly.

## TWINE REMOVAL

Before attempting the removal of twine from the rotor, be sure that the

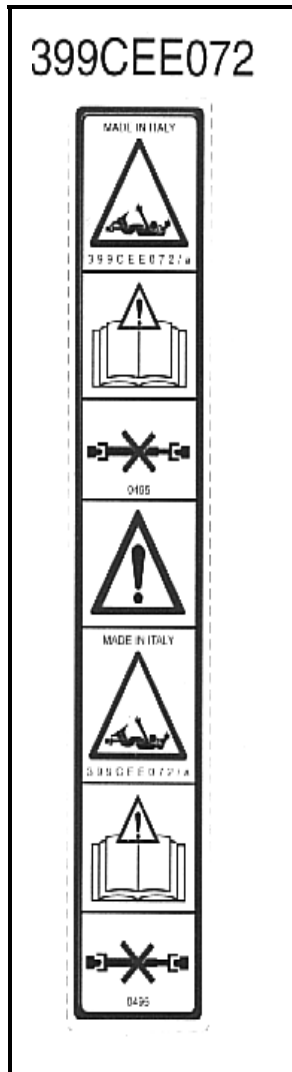

machine is stopped and the tractor is shut off. Place the

tractor in park. Twines can be removed with the use of a utility knife or other knife. An electric device is also available from some suppliers that would melt the twine and allow it to be pulled off. It is **NOT ALLOWED** to burn the twine from the rotor as this has several adverse effects:

- 1) It may take the temper out of the steel, rendering it weaker.
- 2) Loose straw and hay remaining in the machine may ignite causing a fire in the processor.
- 3) Excessive buildup of melted plastic.
- 4) Dry out bushings causing them to wear prematurely.

**NOTE: Bridgeview Manufacturing Inc. VOIDS warranty if twine burning occurs.**

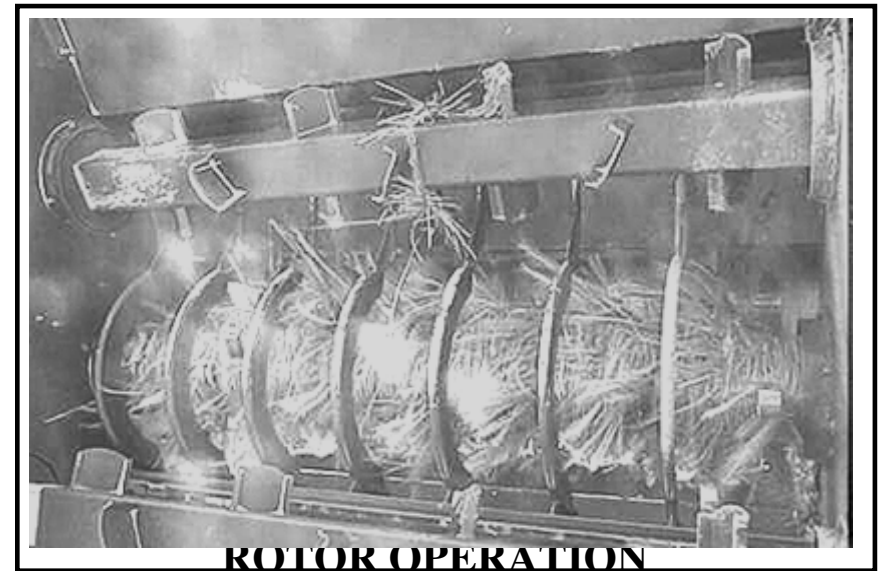

To engage the rotor for processing of a bale, be sure the PTO shaft is properly connected to the tractor. Tractor must be at idle speed when engaging the PTO. After the PTO has been fully engaged, increase pto speed

until it has reached 1000 RPM. Running the processor at any speed less than 1000 PTO RPM may result in the flails springing back against the rotor after they have come in contact with the bale. This “backslap” may cause flails to fatigue and excessive vibration which may cause bearing failure. Bales may be dumped into the tub while the rotor is stopped or while it is running

## ROTATION OF BALES



The Bale King is equipped with a flow divider/combiner and two hydraulic motors for turning the bale.

Once the main rotor is turning at full speed the bale can be turned in either direction to begin processing. The faster the bale is turned in either direction, the faster it will be processed.

It may be necessary to change direction of the bale when loose debris builds on either side of the bale chamber. This will remove the loose debris preventing spillage from the machine.

This is especially true when processing soft core bales. By reversing direction regularly, soft core bales will process more evenly.

When the first bale has been processed, it is common practice to leave the rotor turning at full speed when loading the second bale into the bale chamber from the rear forks.

If the tractor has a flow control, start at a low rate. Turning bales too fast can result in rotor overloading resulting in flail backslap which in turn causes flail and bushing damage.

must turn freely on the driveshaft.

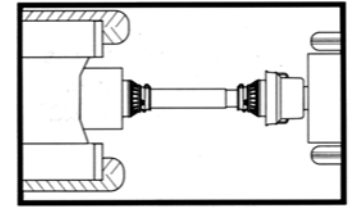

Before operating the machine, be sure drive-lines are attached **securely** to the tractor and to the implement. Check the tractor yoke.

Keep operators and bystanders away from all moving parts.

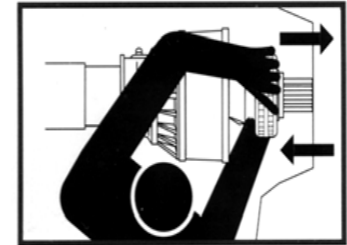

**NOTE: Contact with a rotating drive-line can cause serious injury or death.**



## PTO USE AND MAINTENANCE

Do not operate the machine without all driveline, tractor, and implement shields in place. Drive-line shields

### **Safety:**

Shut off the tractor engine and remove the key before doing any

maintenance on the machine. Use **genuine Bondioli & Pavesi parts when replacing any worn or damages PTO components.**

**Length:**

Confirm the minimum and maximum working lengths of the drive-line. The telescoping tubes must overlap at least 1/3 of their length when in use.

**Shielding:**

Be sure that the shielding is not damaged and rotates freely on the drive shaft.

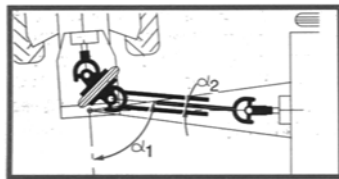

**Working Angles:**

Constant Velocity joints can operate up to 80 degrees for short periods of time. Do not operate for long periods on sharp angles.

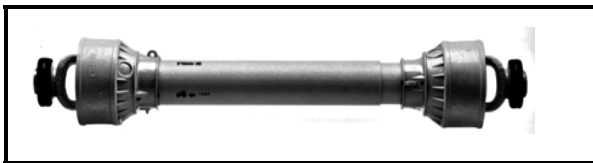

7

**DEFLECTORS**

**SIDE DEFLECTOR ADJUSTMENT**

Your new Bale King is equipped with a hydraulic deflector and an electric diverter valve. This allows you to use only two remotes on

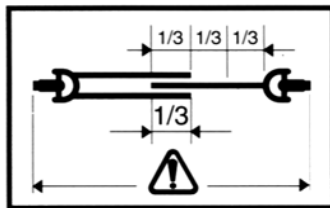

your tractor. The rear fork, side deflector, and wing/feed are operated by the same hydraulic lever. The middle position on the switch operates the rear forks. The deflector or wing/feed operates when you move the switch to that position. The deflector position is standard on all models, while the wing/feed is used only on 4000,4100 or 3010,3110 models.

The control box requires 12 volt power. The **Black** wire is power and **White** wire is ground. **Note** Always attach the control box to **keyed** power to avoid draining the tractor battery when tractor is not being used.



**BOTTOM DEFLE**

Located at the bottom of the discharge which can be adjusted up or down to suit needs. It adjusts with a handle on the front of the Bale King.

- Bedding-** To bed an open area or corral, raise the side deflector to the upper position to allow straw to blow out evenly. The bottom deflector can be adjusted part way up or down to aid in distribution.
- Windrowing-** To window feed along the ground simply lower the side deflector to the desired height and adjust the bottom deflector to the lower position.
- Bunk Feeding-** Adjust the side deflector to clear the bunk and raise the bottom deflector up to throw the material up against the deflector. Drive along the bunk and process.

**HOOP GRATE ADJUSTMENT**

There are seven adjustment settings for the hoop grate on the Bale King bale processor. These settings determine the rate of feed of the bale you are processing and the how fine the cut will be.

**Position #1-** Highest grate setting for finest cut and slowest rate of feed.  
Used for tough processing feeds such as silage bales and some types of hay.

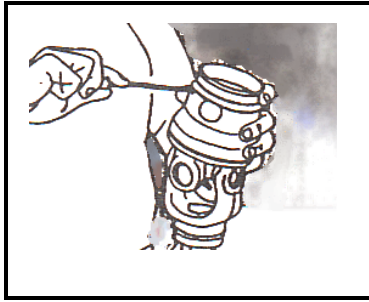

**Position #2 -#6-** Normal operating range. Machine gets more aggressive as grate is lowered.

**Position #7-** Lowest grate position, Most aggressive fastest rate of feed.

The Bale King should be adjusted according to various bale conditions to achieve a rate of feed of approximately **1.5 to 2 minutes**. Light brittle material such as wheat straw may allow faster processing while tough stringy material such as slough hay, green feed, or flax will require slower processing. Hoop grate adjustment should be checked periodically.

**NOTE: Processing a bale more rapidly than this may cause unnecessary machine deterioration.**

**NOTE: Upper grate position should approximately -1/4” flail protrusion. Lower grate should allow 1 1/4” flail protrusion. Contact your Bale King dealer if this can’t be achieved.**

The grate assembly can be removed from the machine by removing the linkage bolts and the 3/8 bolts on the opposite side. the grate will lift out the top.

**Attachment:**

Be sure the drive-line is properly attached and all bolts and screws are tight on the implement input shaft and on the tractor PTO shaft.



**Storage:**

When not in use, cover or protect the drive shaft from the weather. When removed from the machine store both half’s together to prevent damage. check all components for proper function and lubrication before use.

**BEFORE ATTEMPTING ANY REPAIR PROCEDURES, ALWAYS USE APPROPRIATE EQUIPMENT SUCH AS SAFETY GLASSES, SAFETY SHOES, AND GLOVES.**

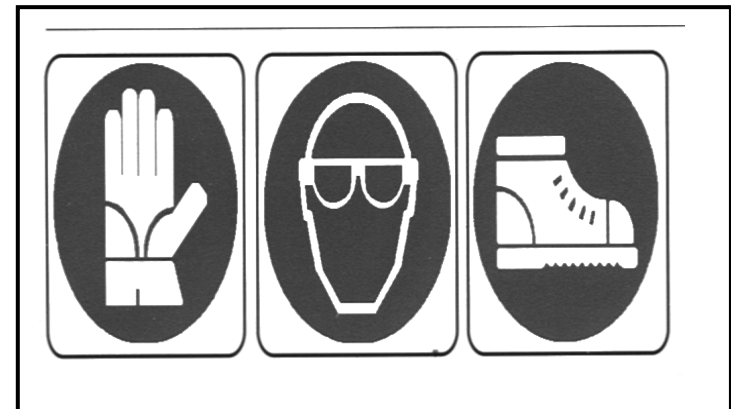

### Shield Removal

To remove the shield, push down on cone and press in the three tabs to disengage the locking nylon bearing. Slide shell off tube.

Remove the nylon bearing to remove the plastic tubes.

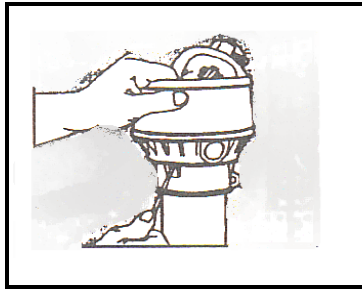

To remove the shield over the CV joint, remove the screws which split the shield and drop the half over the shaft.

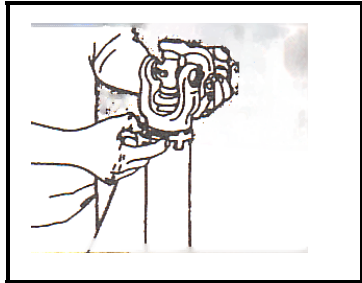

### Shield Assembly

Be sure to lube the groove in the inner yokes where the shield bearing rides. Re-install shields in the above directions in reverse order.

The new adjustable hitch on the Bale King features a casted single tongue with hammer strap insert. This allows the use with tractors equipped with the hammer strap or with the single drawbar. This allows the machine move independently over rough terrain without bending the draw pin.

Adjust hitch height for proper PTO alignment and level of machine front to rear.

## HYDRAULIC HOOKUP

### Standard:

There are four hydraulic hoses to be connected to the tractor. The two hoses running to the back of the Bale King operate the loading forks and the side deflector. These hoses will be marked with a blue band on each hose.

The other two hoses run the beaters and are marked with a red band on each hose.

The drive shaft is shear-bolt protected. The machine must be operated at **1000 PTO RPM.**

**NOTE: Spread yokes and twisted drive shafts are signs of overload, not a manufacturer's defect and therefore not covered by warranty.**

## TWINE GUARDS

The main rotor and the beaters are equipped with removable twine guards. The guards are mounted to the front and rear wall of the machine. The twine guards are bolted and need to be removed if you need to remove or tighten the bolts on the bearings or the hydraulic motors.

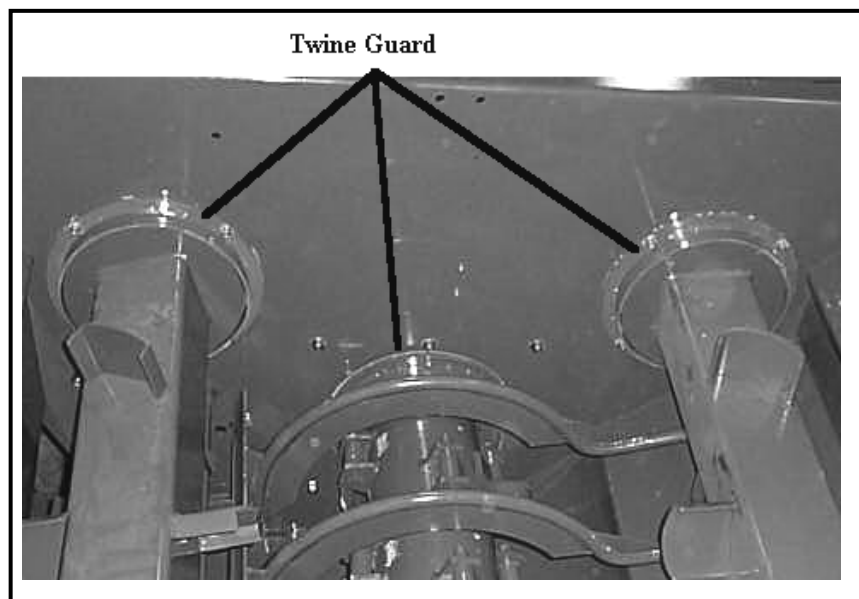

Frequent lubrication is required. Grease the driveline parts as required on the chart.

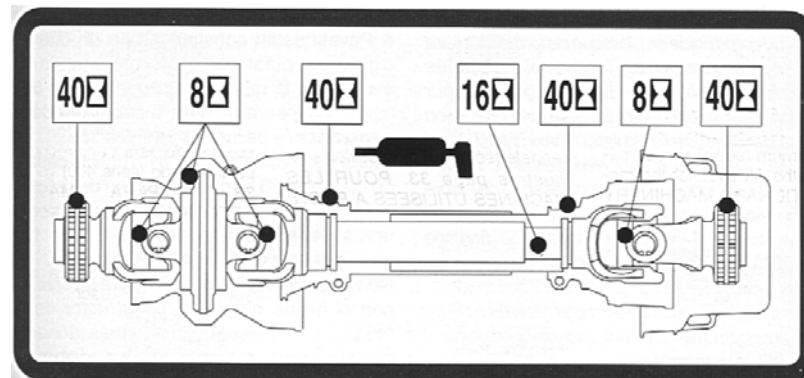

**After Storage** for long periods of time, lubricate and check the function of every driveline component before operating.

**Check** to see that all locations are lubed as per chart. Failure to grease all the joints will **void** warranty.

Lubricating the Bale King bale processor should be done on a regular basis.

The grease zerks are located:

- on each end of the main rotor bearing blocks (grease every 250 bales).
  - on the beater bearings on the back of the tub (grease every 250 bales).
  - on the bale fork pivot (2 grease zerks every 250 bales).
- wheel hubs (seasonally), or more often if traveling long distances.

The 3000 series **Bale King** processors have an optional fine chop knife kit available to go into the lower tub area. This option is available if you require a shorter cut on the material which you are processing such as slough hay and silage bales.

It is recommended that the knives be lowered when bedding straw as it will affect your spread pattern. Adjust the machine as needed.

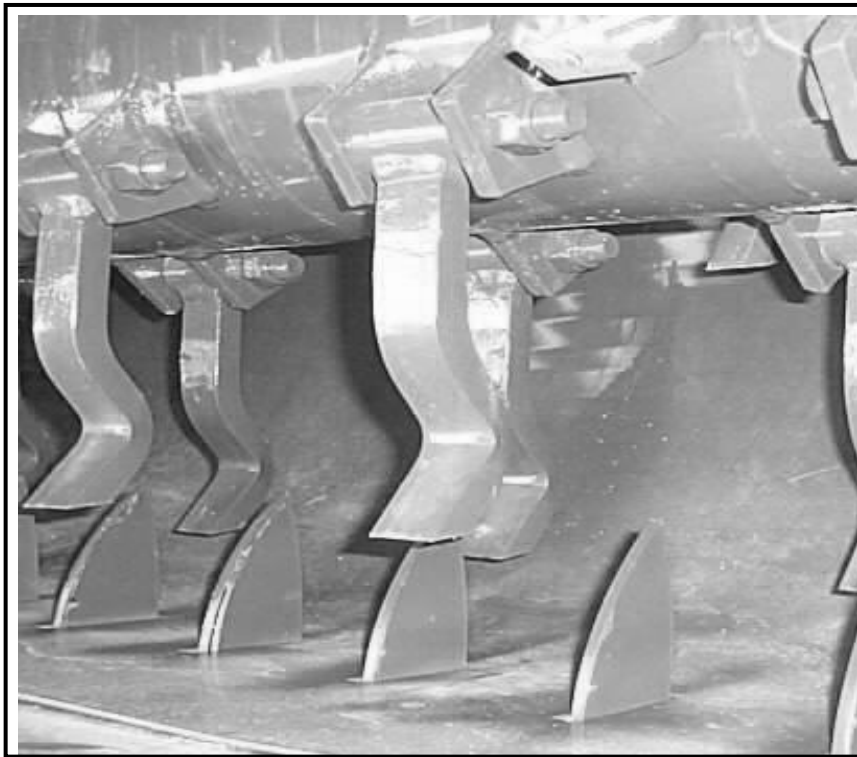

11

## LOADING BALES

When loading bales into your Bale King bale processor, the following procedure should be followed:

- Position the tractor and the Bale King so as to be lined up to back straight into the row of bales.
- When close to the bale, lower the forks totally (you will feel a slight vibration as the forks bottom out against the frame.)
  - Back completely under the first bale.

- Allow the tractor to push forward while lifting the bale, because the bale fork moves away from the machine while loading. If you are loading from the same row you can dump the bale into the machine and back straight back for the second bale. If you are going to a different stack for the second bale only raise the first bale enough to clear the ground. Move to the next row and align the machine to the bale before dumping the bale into the tub. This gives you good visibility to line up to the second bale.

- Once you have the first bale in the tub and the second bale on the forks, raise the bale fork about  $\frac{1}{4}$  of the way up. You now can transport to your feeding area to begin processing. **Note:** Carry the bale as low as possible so that there is less stress on the cylinder shafts. Carrying the bale high may bend hydraulic cylinder shafts.



WH

ED

Wheel bearings should be inspected periodically for adjustment

16

and lubricated annually.

To tighten the wheel bearings, lift up each wheel( one at a time) until the wheel spins freely. Remove the dust cap and the cotter pin which retains the nut. Tighten the nut until the wheel will rotate approximately two turns when given a firm spin. Align the castle nut to the closest hole and insert the cotter pin. Re-install the dust cap and lube if required.

Check and remove any twine which may wrap around the spindle.

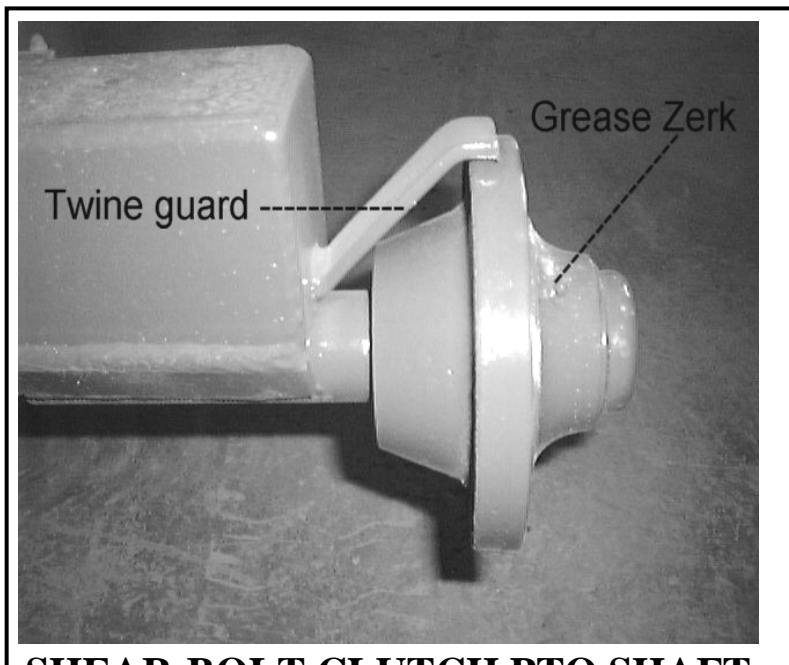

**SHEAR-BOLT CLUTCH PTO SHAFT**

All new Bale King Processors are equipped with a shearbolt

clutch located at the machine end of the PTO shaft. The shear-bolt is **10mm x 60mm grade 8.8**. The **metric shear-bolt** must be used. Any other size will damage the shear assembly.

If your shear-bolt is shearing excessively you may be over-loading the machine. If this occurs raise the grate assembly to make the machine less aggressive. Also roll the bale more slowly.

**Always ensure that your machine is running at 1000 PTO RPM.**

NOTE: Please consult your local dealer to help pinpoint any problems.



**GEARBOX MAINTENANCE**

There is one grease nipple on the front of the gear box. Apply 2-3 strokes of grease every **8 hours**.

The gearbox requires 80W/90 gear oil with a capacity of approximately 500 ml. The oil should be filled to the level plug and checked on a regular basis. The change interval is as follows:

- Change oil **25** hours after first use.
- Change oil **25** hours after first change(**50 hours** of use from new). Change every **300** hours after or **yearly** which ever comes first.

## TIRE INFLATION AND PLY RATING

The proper tire inflation for Model 3100 with standard 11Lx15 8 ply tires is **35 psi**. Proper tire inflation will help alleviate a puncture problem when pulling and operating the machine on rough terrain.

Proper inflation for the optional tire 31/13.50x15 turf tire is **35 psi**.

**Maximum speed for agricultural tires is 25 mph or 40 kmh**

**NOTE: Check and tighten wheel bolts regularly to ensure that bolts are tight!**

Warranty **does not** cover damaged rims and hubs due to loose wheel bolts. Tire warranty is covered by the **Tire Manufacturer**

## PTO HOLDER

A PTO shaft holder is standard with your new Bale King, for safe storage of the shaft when processor is not in use.

When unhooking the PTO shaft from the tractor, lift the free end of the PTO shaft up and place it in the holder provided. This will keep the shaft away from the hitch when hooking the tractor to the machine and keep it clear from snow and ice.

## PTO HOOKUP

Your Bale King Processor has a PTO shaft which is splined on both ends.

The machine end uses a 1 ¾ -20 spline with wedge lock bolt. Install on the machine and tighten the wedge bolt. **Wedge bolt should be tightened to 160 ft/lbs. and re torqued after 8 hours of use.**

The tractor end comes standard with a 1 3/8-21 spline quick detach constant velocity joint. An optional 1 ¾ spline yoke is available from your Local Bale King Dealer.

**Never** operate your processor with a PTO adaptor. Any resulting damage is not warranty.

**Always** ensure that the PTO shaft is attached securely to the tractor. When the processor is not hooked to the tractor store the shaft on the PTO holder.

**Do Not** transport the processor without securing the PTO shaft. It may bounce off the holder and be damaged.

**Always** ensure that the drawbar is adjusted to **16"** from the end of the tractor PTO shaft to the center of the hole in the drawbar